



Flowform[®] Learn Lounge

Double Seat

MODEL#: 55011



OVERVIEW

Flowform Learn Lounge Double Seat provides comfort to students due to the 103° angled seatback that offers support in a position appropriate for the desired work mode. Pair with our Flowform Learn Lounge Tables and Screens to create individual zones for student engagement and learning.

MATERIALS

The STRUCTURE is constructed of plywood frame which is made from Sustainable Forestry Initiative (SFI) certified responsible wood sources. The seating pad is made from high density foam meeting CAL 117 standards and contains no added flame retardant chemicals. Comes with reversible nylon & felt glides.

The FABRIC is Designtex Alphabet 100% vinyl, with a 1,000,000 D.R. Durability rating. The backing of the fabric is Polyester. The fabric is highly durable and is easily cleanable with a 10:1 Water:Bleach mixture.

WEIGHT CAPACITY 550 lbs

STANDARD VINYL COLOR OPTIONS



VINYL COLOR OPTIONS WITH LEAD TIME:



Custom Materials Program Available – Contact Us for Details

DIMENSIONS

Model	Description	D"	W"	H"	F.C.	Cube	WT
55011	Flowform Learn Lounge Double Seat	29.25	58.5	18			79

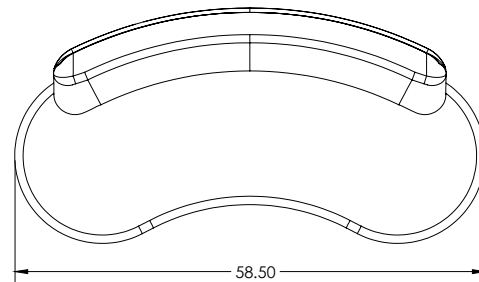
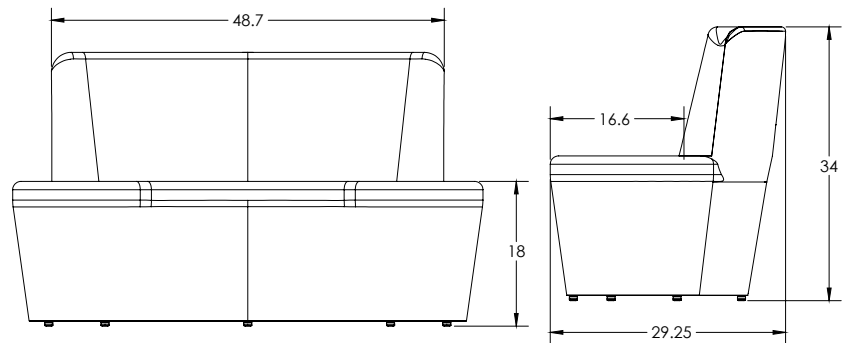

DESIGNTEX

PATTERN	Alphabet
CONTENT	100% Vinyl
BACKING	Polyester, Knit
FLAME RESISTANCE	CA Bulletin 117-2013
DURABILITY	1,000,000 D. R.
MAINTENANCE	W: Bleach Cleanable (10:1)
FINISH	Advanced Protective Topcoat