

Assembly Instructions

MOTUM TEACHERS DESK

SPLIT HEIGHT RIGHT HAND



MODEL NUMBERS

58020 AND 58022

A digital copy of these assembly instructions can be found at

<https://smithsystem.com/wp-content/uploads/2022/03/MOTUM-TEACHERS-DESK-SPLIT-HEIGHT-ASSEMBLY-INSTRUCTIONS-RIGHT-179718.pdf>

For video assembly instructions, scan the QR code link, or visit

<https://www.youtube.com/watch?v=qKpXYjeZtto>



Hardware and Components

BOX A (60149)

ITEM NO.	DESCRIPTION	QTY
A-1	TEACHER DESK U TUBE LEG ASSEMBLY	1
A-2	SWIVEL GLIDE W/ GLIDE STOP	2
A-3	TEACHER DESK STRAIGHT TUBE LEG ASSEMBLY	1
A-4	TD BRACED L BRACKET	1
A-5	TD STRAIGHT TUBE LEG Z BRACKET	1
A-6	TD BOLT ON L BRACKET	1
A-7	TD SIDE PANEL CLIP	2

ITEM NO.	DESCRIPTION	QTY
A-8	TD U TUBE LEG Z BRACKET	1
A-9	TD L BRACKET FRONT 120	1
A-10	TD FILLER BRACKET	2
A-11	TD L BRACKET FRONT MAIN	1
A-12	TD FRONT MAIN TO 120 SPACER	1
A-13	TEACHER DESK HARDWARE PACK	1
A-14	TD FIXED HEIGHT SHIM	4
A-15	12" PENCIL/PAPER RETAINER	1

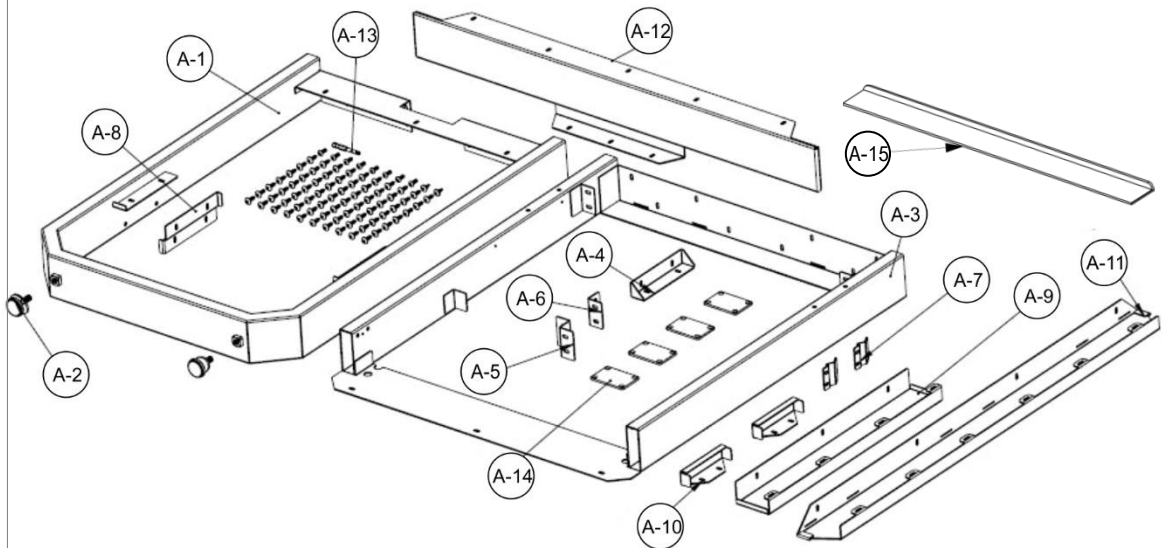

ITEM NO.	DESCRIPTION	QTY
1	Vibration-Resistant Catch	1
2	Vibration-Resistant Strike Plate	1
3	NO.8x3/4" PHILLIPS/SLOTTED WOOD SCREW	2
4	NO. 4 X 1/2" PHILLIPS/SLOTTED WOOD SCREW	2

ITEM NO.	DESCRIPTION	QTY
5	TD SUPPORT BRACE	1
6	TD SUPPORT BRACE HARDWARE PACK	1

(60152)

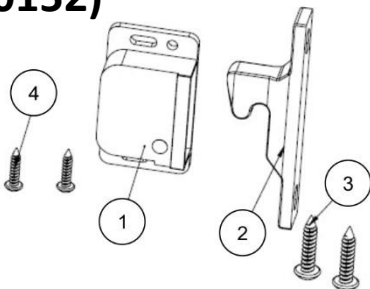

(60151)

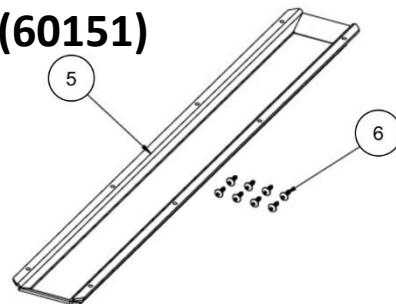

For 72" Model Only (58022)

Hardware and Components

BOX B (60150)

ITEM NO.	DESCRIPTION	QTY	ITEM NO.	DESCRIPTION	QTY
B-1	TD SPLIT HEIGHT BASE ASSEMBLY	1	B-7	TD SPLIT HEIGHT ANGLED PANEL	1
B-2	TD DOOR HINGE ASSEMBLY	1	B-8	TD BOLT ON L BRACKET	5
B-3	SPLIT HEIGHT COSMETIC COVER SIDE	1	B-9	MWS TD WELD ON L BRACKET	1
B-4	SPLIT HEIGHT SPACER	1	B-10	BUTTERFLY PLATE WITH HARWARE PACK	1
B-5	MWS TD LOCK ASSEMBLY	1	B-11	TD SPLIT HEIGHT HARDWARE PACK	1
B-6	SPLIT HEIGHT COSMETIC COVER FRONT	1	B-12	MWS TOD TILT SUPPORT ASSEMBLY	1

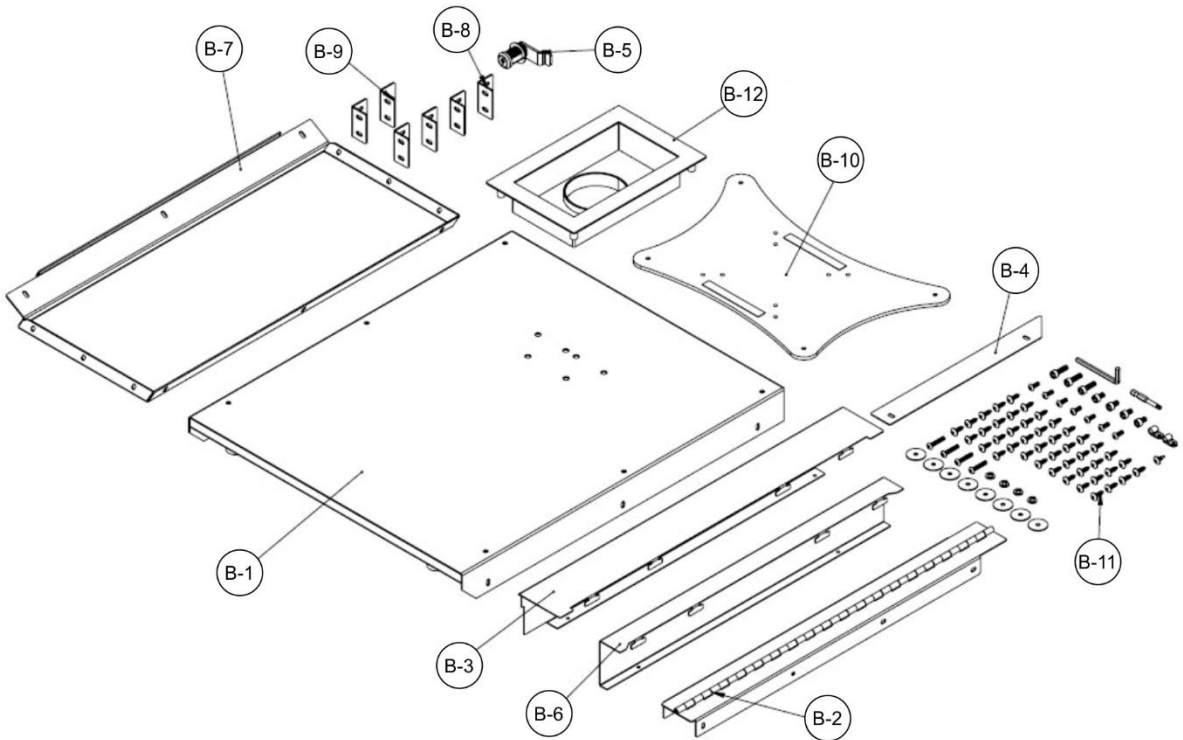

ITEM NO.	DESCRIPTION	QTY
7	2" Caster No Lock w/ 7/16" Friction Stem	2
8	2" Caster w/Lock 7/16" Friction Stem	2

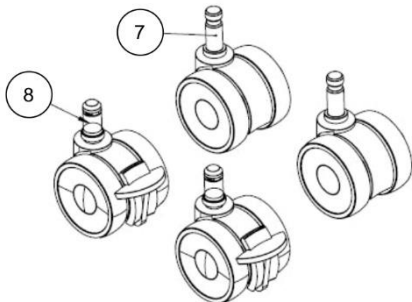

ITEM NO.	DESCRIPTION	QTY
9	TD SPLIT LAMINATE COVER RH SIDE	1
10	TD SPLIT LAMINATE COVER RH FRONT	1
11	SIT-STAND DESK FLIP TOP COLUMN	1

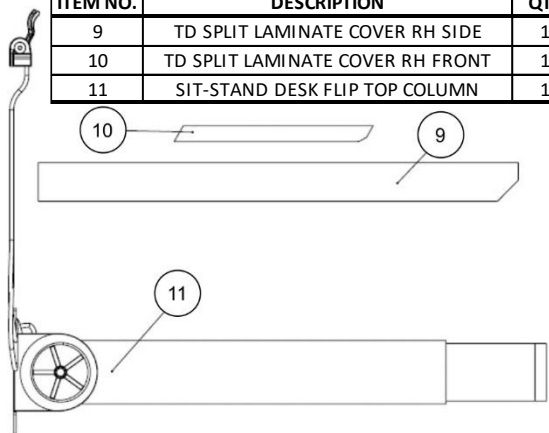

Hardware and Components

BOX A ITEM #A-13 (60139) – TEACHERS DESK HARDWARE PACK COMPONENTS

ITEM NO.	DESCRIPTION	QTY
13-1	NO. 10 X 5/8" TORX BUTTON HEAD SCREW	70
13-2	NO. 10 X 1/2" TORX SELF DRILLING BUTTON HEAD SCREW	2
13-3	10-32 X 1/2" TORX BUTTON HEAD W/PATCH	8
13-4	T25 TORX POWER BIT #2	1

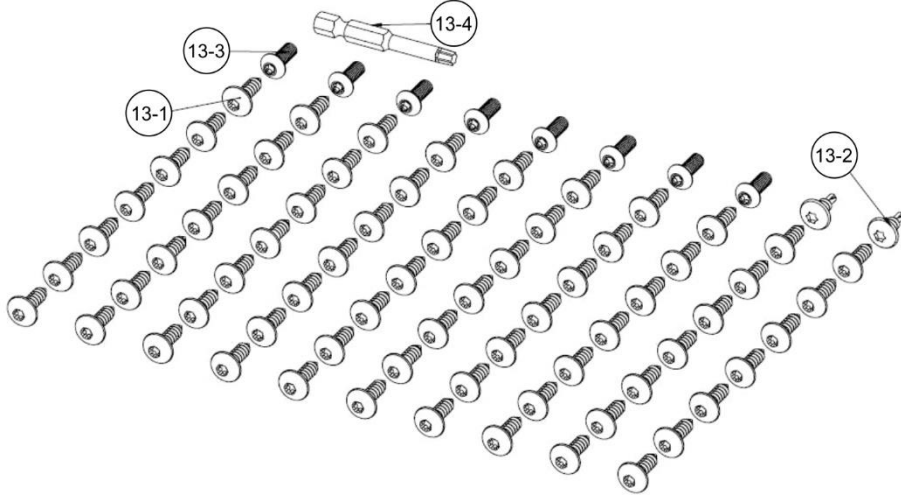

BOX B ITEM #B-11 (60140) – TD SPLIT HEIGHT HARDWARE PACK COMPONENTS

ITEM NO.	DESCRIPTION	QTY
11-1	NO. 10 X 5/8" TORX BUTTON HEAD SCREW	44
11-2	NO. 10 X 1/2" TORX SELF DRILLING BUTTON HEAD SCREW	1
11-3	10-32 X 1/2" TORX BUTTON HEAD SCREW W/PATCH	7
11-4	M6 X 1.0 X 20MM SOCKET HEAD, HEX DRIVE, BLK OX	3
11-5	M6 X 1.0 X 10MM SOCKET HEAD, HEX DRIVE, BLK OX	4
11-6	1/4" I.D. PLASTIC LOOP CLAMP	2
11-7	HEX KEY 5MM SHORT ARM	1
11-8	T25 TORX POWER BIT 2"	1
11-9	10-32 X 1" TORX BUTTON HEAD W/PATCH	4
11-10	#10 WASHER 1" od	8
11-11	M6 SPLIT LOCK WASHER	4

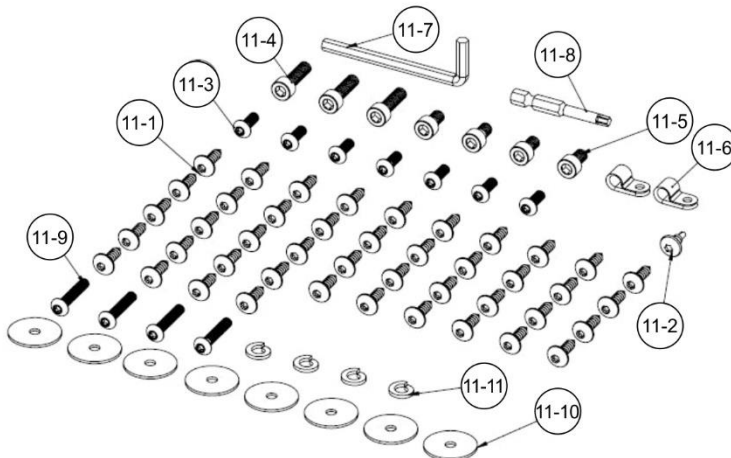

Hardware and Components

PANEL LETTER	DESCRIPTION	QTY
A	TD STRAIGHT LEG SIDE PANEL	1
B	TD U LEG SIDE PANEL	1
F	TD MAIN FRONT PANEL RH	1
G	TD 120 FRONT PANEL RH	1
J	TD SPLIT 24X36" TOP RH	1
K	TD SPLIT 24X24" TOP	1
P	TD SPLIT SIDE PANEL RH	1
Q	TD SPLIT DOOR RH	1
R	TD SPLIT SHELF RH	1
S	TD SPLIT MIDDLE PANEL RH	1
U	TD SPLIT 24X45" TOP RH	1

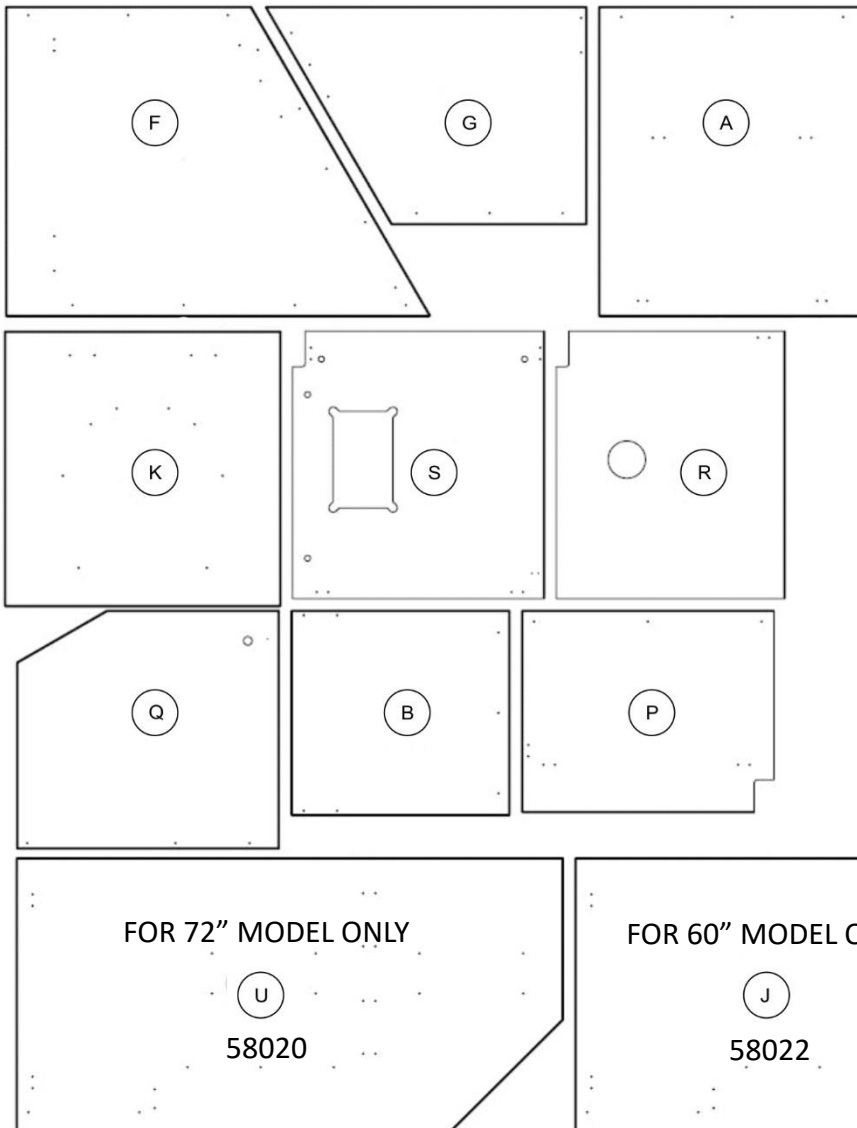

General Assembly Guidelines

Special Notes:

- Ensure that all components are accounted for and undamaged before assembling
- Follow each step carefully to ensure the proper assembly of this product
- 2-person assembly is highly recommended
- Clean the product with a mild cleaner and damp cloth

Tools:

- Framing Square
- Drill
- #1 and #2 Phillips bit
- Adjustable wrench
- Hammer
- Screwdriver (optional)
- Wood Clamps (optional)
- ¼" bit extender (optional)

Assembly Instructions

1. Place wood top on clean smooth surface upside down with the pilot holes facing up, fasten 2x item #A-7 to item A using 4x fasteners item #13-1 using the supplied T25 Torx bit item #13-4.

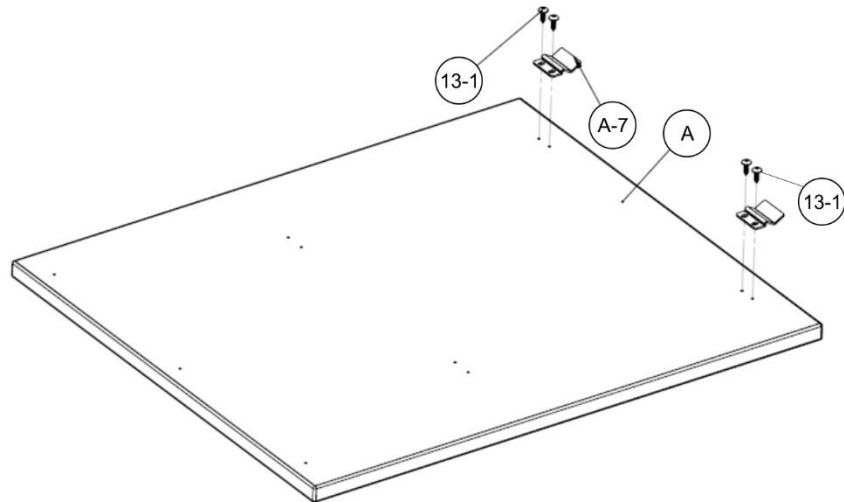

2. Slide the previously assembled panel A onto item #A-3, item #A-7 should slide over the metal lip of item #A-3 as shown. Do not install any fasteners at this point this board will be removed later. It is helpful to clamp panel A to item #A-3.

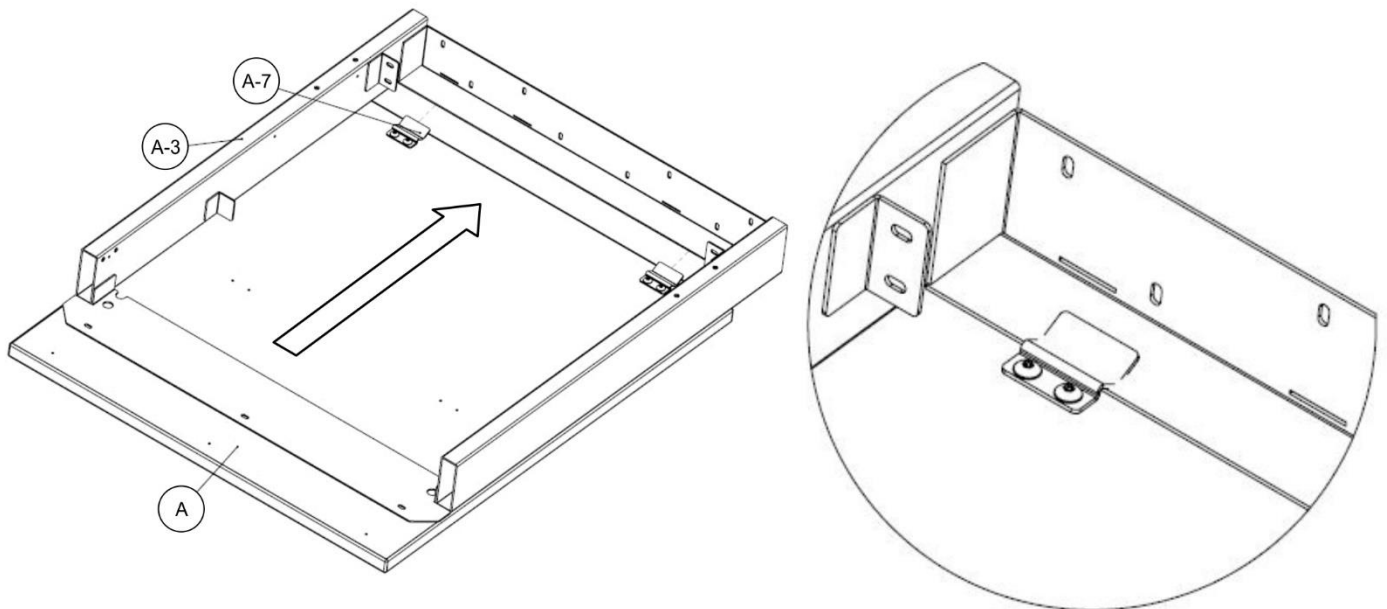

Assembly Instructions

- Using previously assembled components install item #A-4 and #A-5 using 4x fastener #13-3, do not fully tighten, install item #B-2 using 3x fastener #13-1 note to orientation of #B-2, do not fully tighten.

Optional: Use 1x fastener #13-1 to hold #A-3 in place. This fastener will be removed on step 10

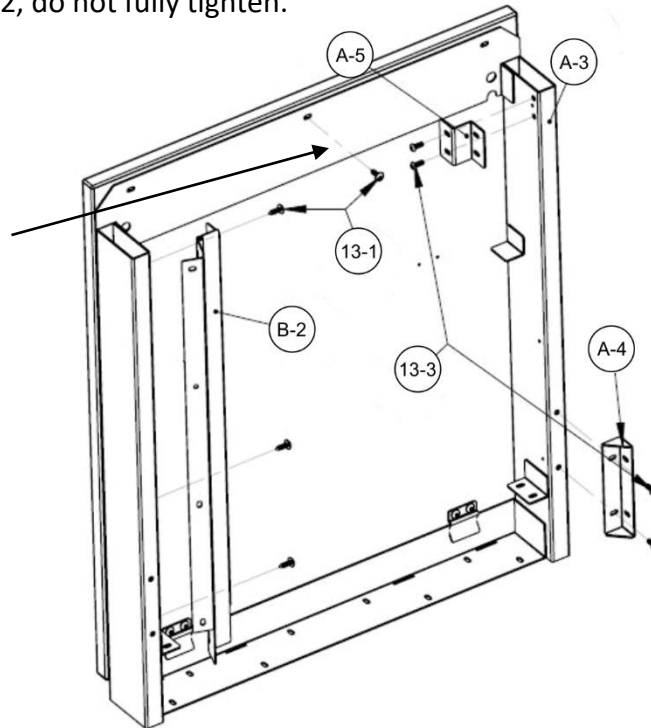

- Position Panel B as shown, centering the panel to create equal gaps, a spacer or credit card works well. Fasten panel B to item #A-1 using 7x fasteners item #13-1 using the supplied T25 Torx bit item # 13-4. NOTE: The panel should sit on the metal finger as shown in detail.

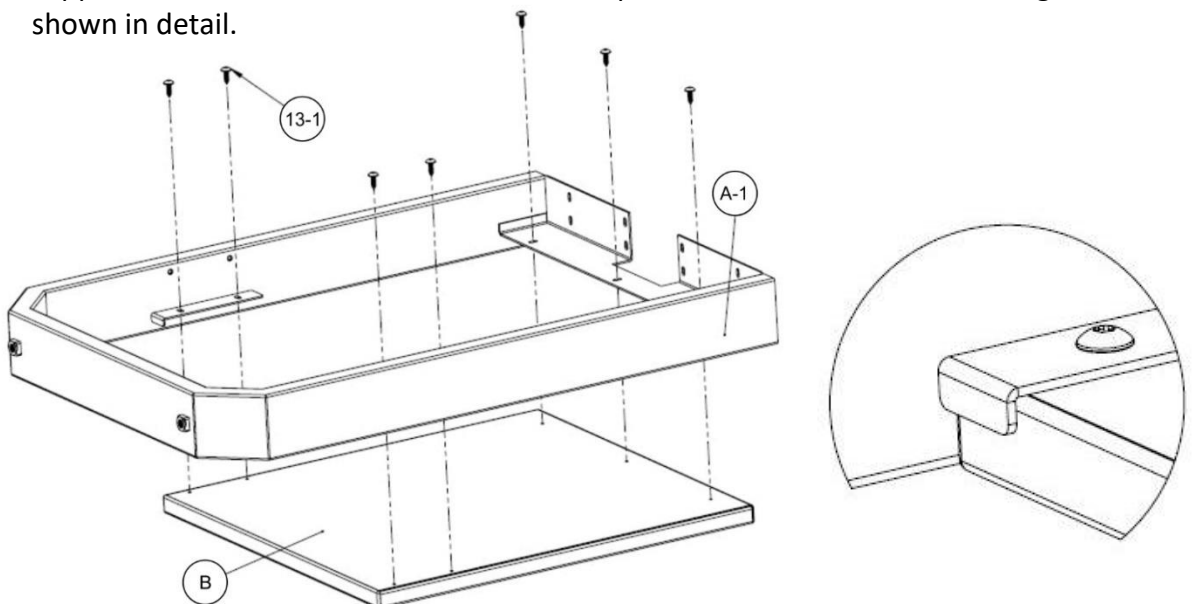

Assembly Instructions

5. Fasten 4x item #B-8 and 1x item #B-9 to panel P using 10x fasteners item #11-1 using the supplied T25 Torx bit item #13-4.

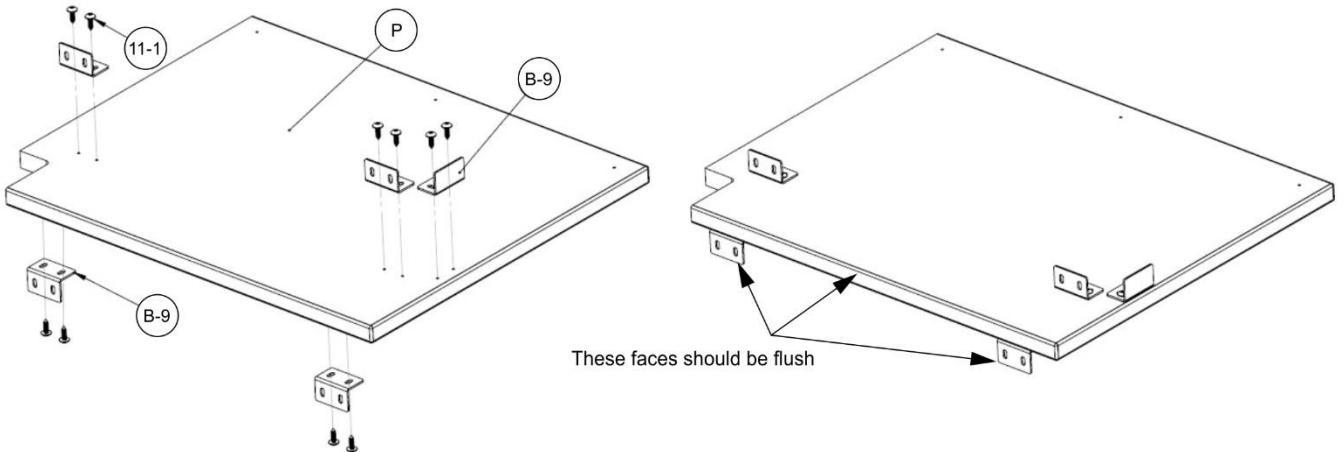

6. Position Panel S as shown over the top of item #B-12. Fasten panel S to item #B-12 using 4x fasteners item #11-3 and #11-10, finger tighten only. Fasten item #1 using 2x fastener #4 as shown.

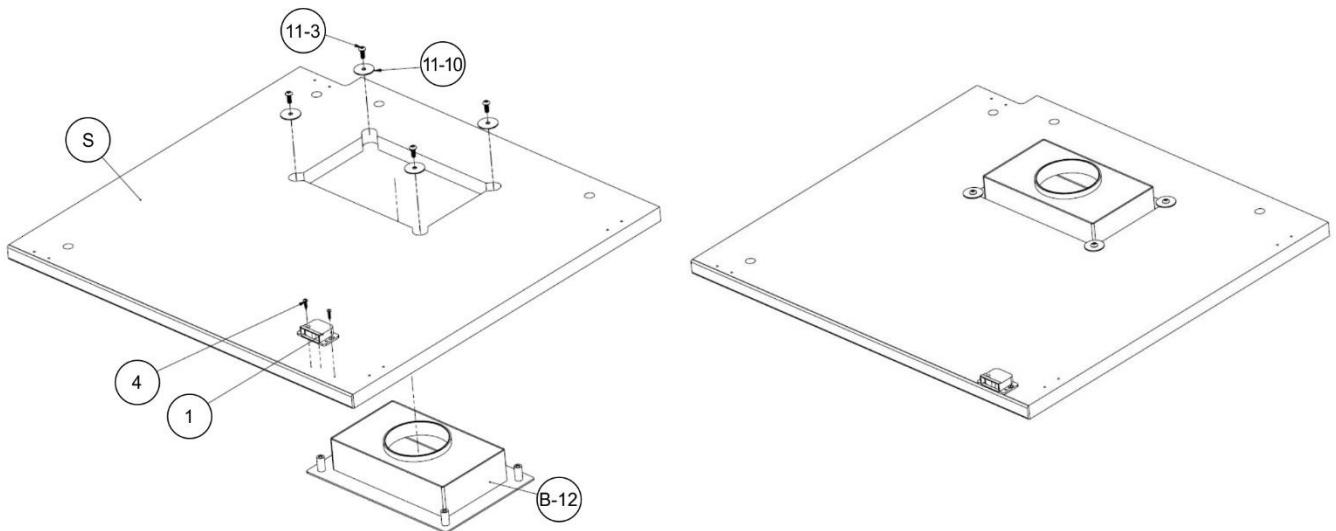

Assembly Instructions

- Using 2x item #A-10 as spacers. Place panel F as shown. Confirm edges of panels F and A align as shown. Fasten panel F with the 2x indicated fastener #13-1. Confirm edges of panels F and A are still aligned before installing the remaining 6x #13-1 fasteners

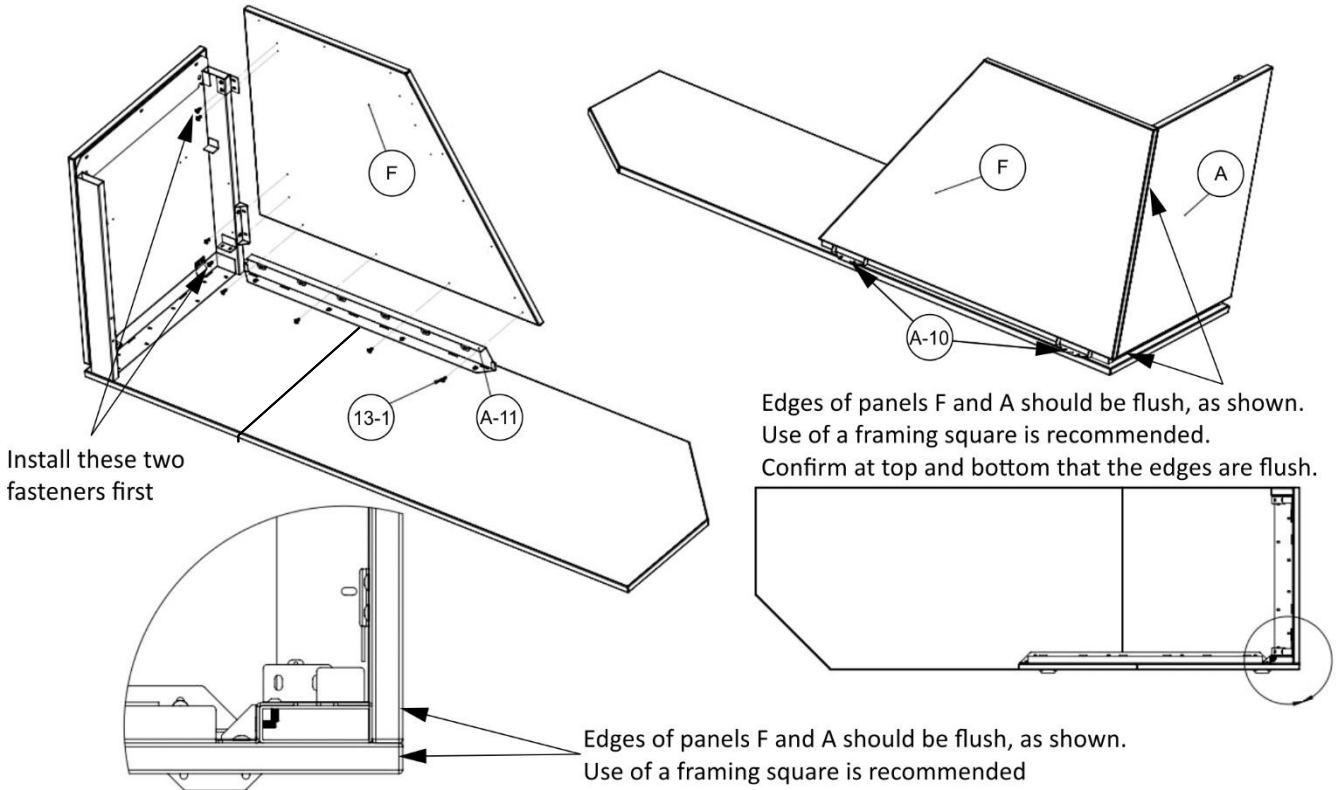

- Place the previously assembled panel S as shown, ensure panel S is below the 4 mounting tabs before sliding panel P into place. **This is the most critical step, ensure all 3 edges of panel S are touching the corresponding edges as shown below.** Fasten panel S and P using 8x fastener #11-1

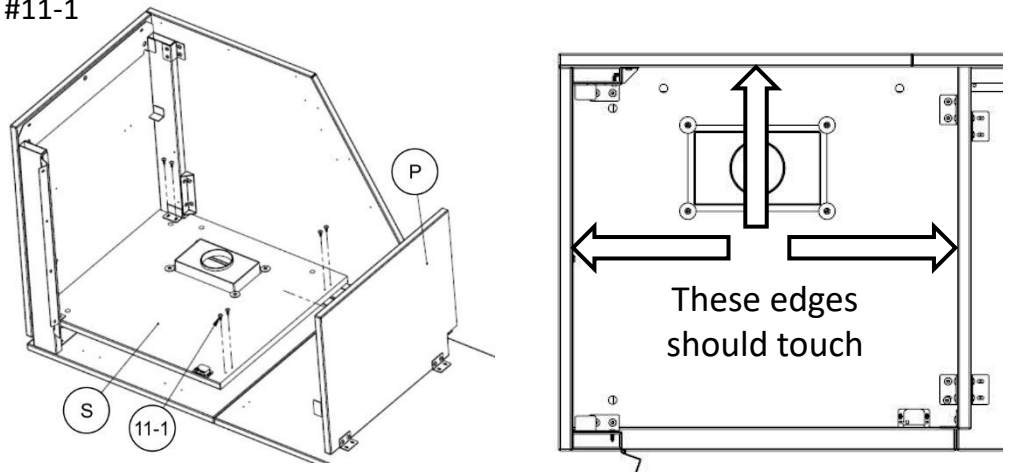

Assembly Instructions

9. Fasten item #B-7 with 6x fastener #11-1, it is recommended to use a square to ensure panel P is vertical.

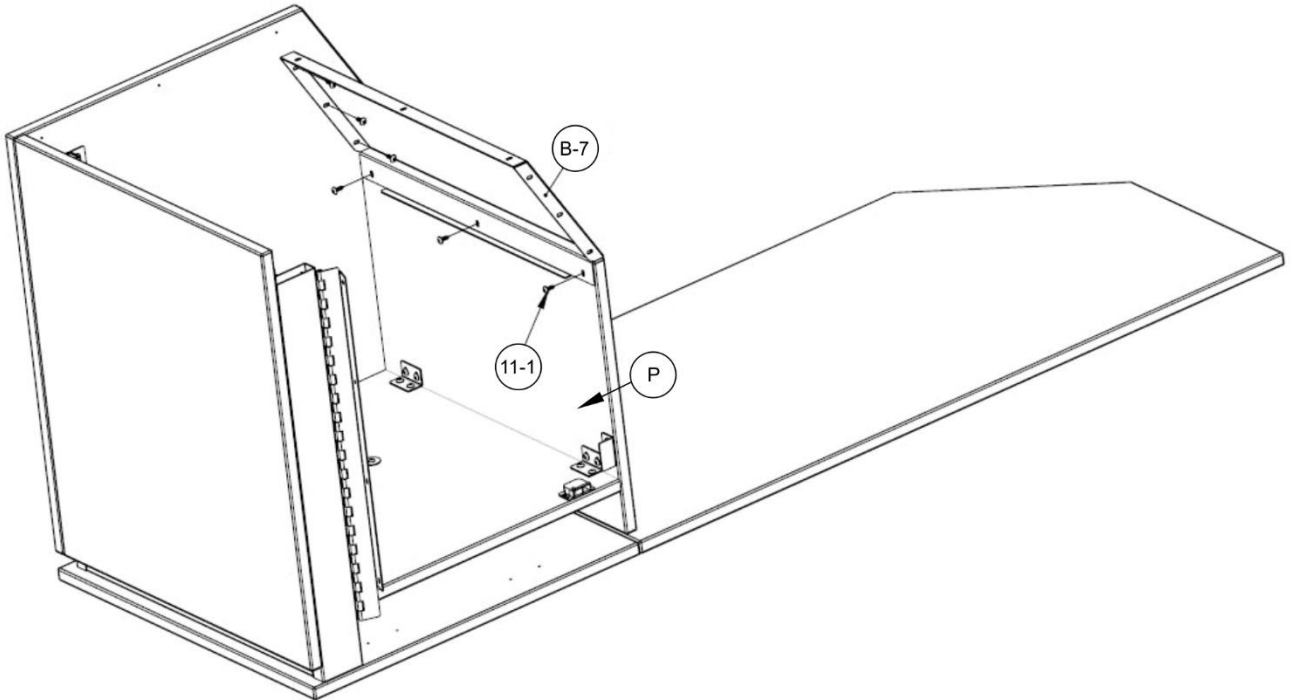

10. Remove noted fastener from step 3. Install item #B-1 as shown using 6x fastener 11-1 and 3x fastener 11-3.

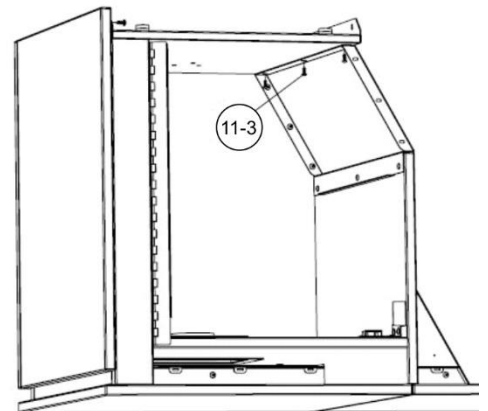
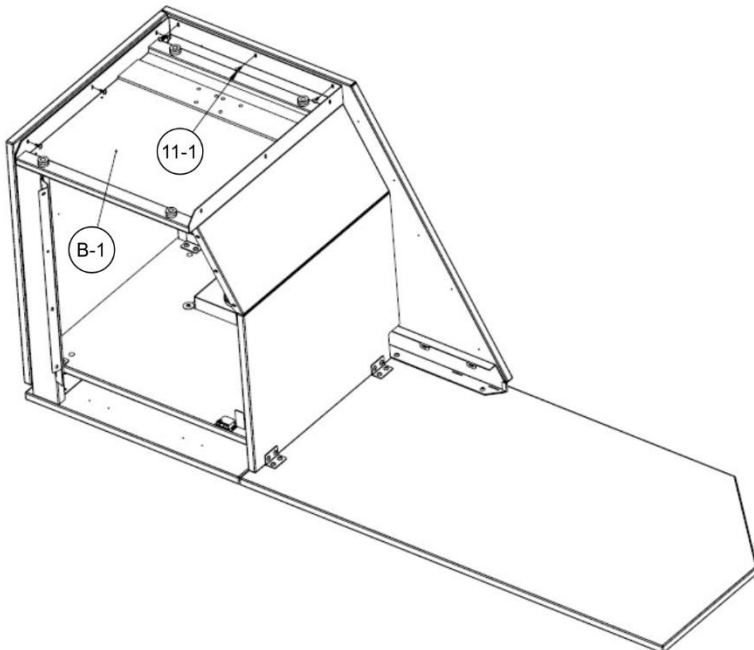

Assembly Instructions

11. Slide item #B-4 under item #A-11. Align the edges of item #A-11 and #B-8 with the reference line as shown. Fasten down using 6x fastener #11-1

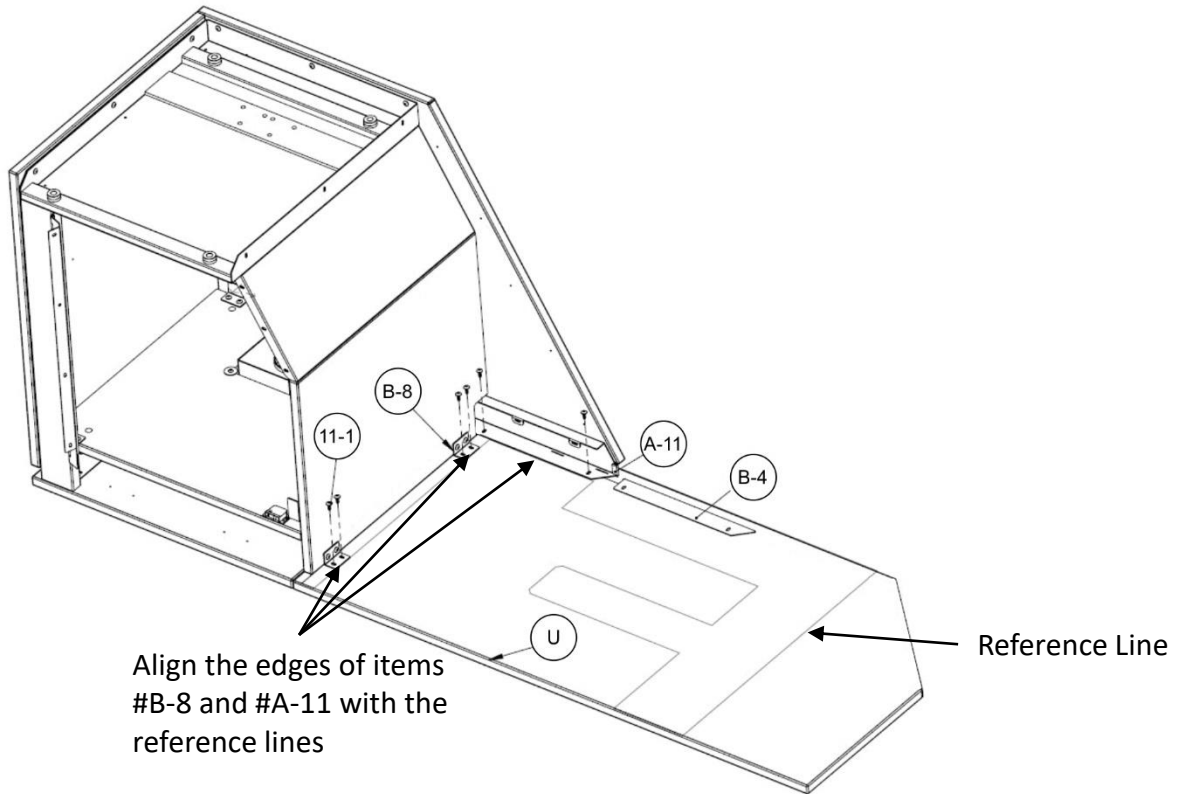

12. Align the edge of item #A-10 with the reference line as shown. Item #A-10 should be touching item #A-11. Fasten #A-10 to top using 2x fastener #11-1.

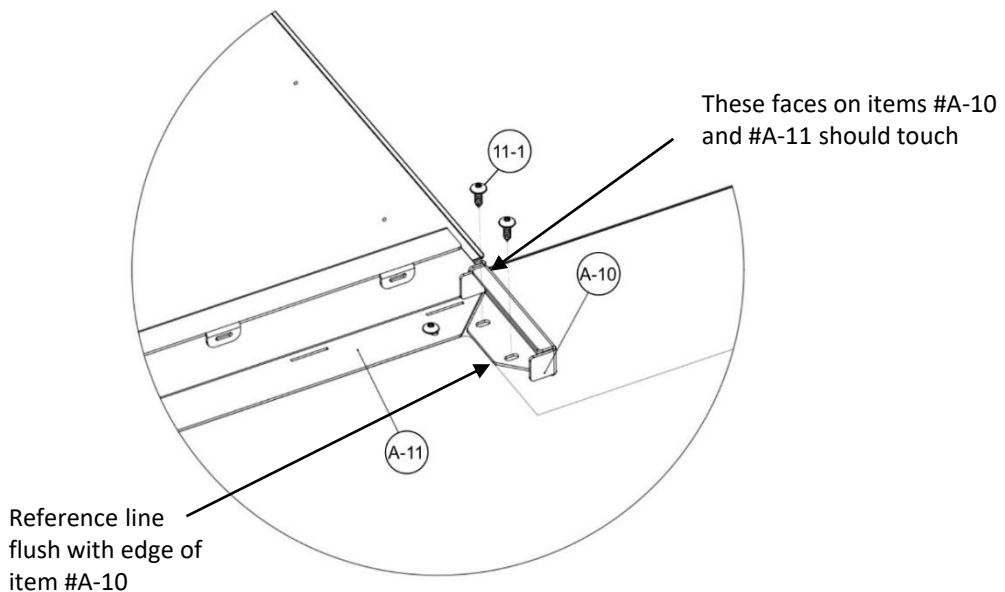

Assembly Instructions

13. Place item #A-12 as shown. Confirm faces of panel F and item #A-12 align as shown. Fasten item #A-12 with the 5x fasteners #11-1.

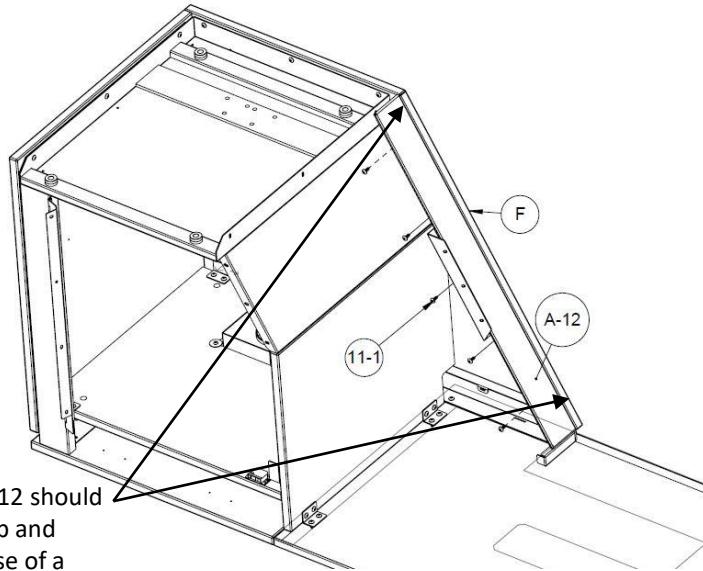

Edges of panel F and item #12 should be flush as shown, check top and bottom before fastening. Use of a straight edge is recommended.

14. Align edge of item #A-9 with the reference line as shown. Item #A-10 can be used as a spacer for panel G. Insert panel G into the slot of item #A-12. Place item #A-9 against panel G as shown. Confirm that all 3x holes on item #A-12 and item #A-9 can be seen through the slots while item #A-10 is in place. Fasten #A-12 and #A-9 to panel G using 3x fastener #13-1 each. (Do not fasten item #A-9 to the panel U, this will be done in future steps)

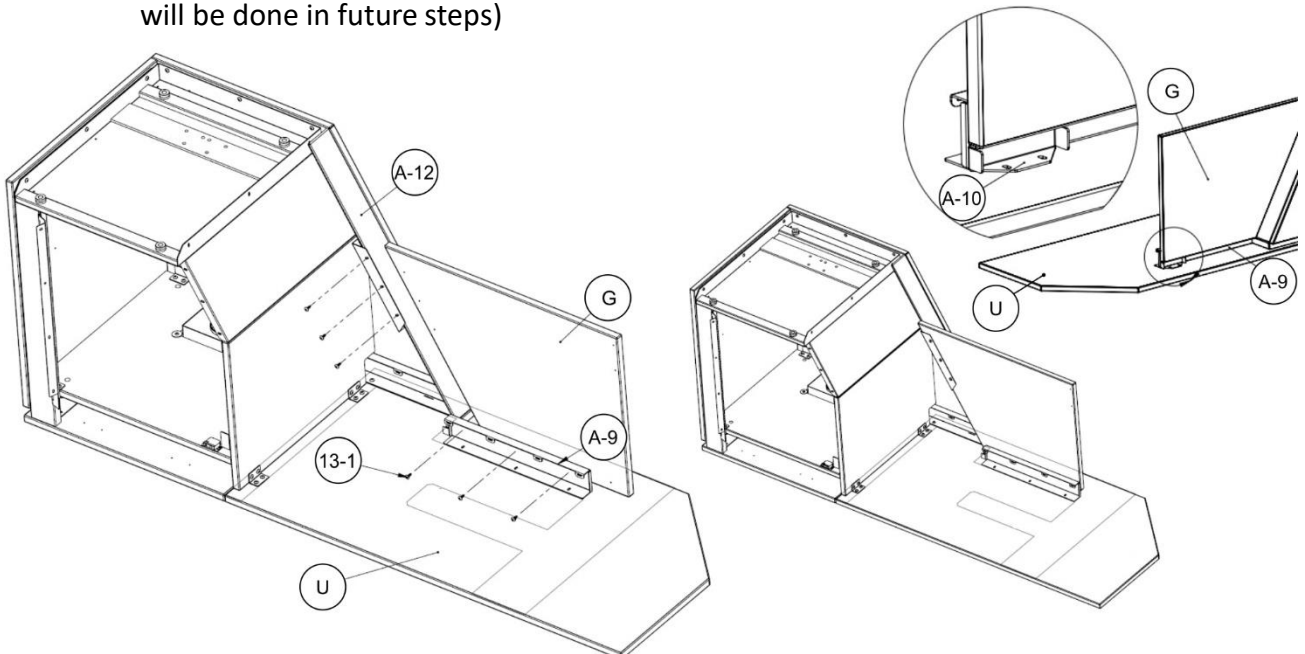

Assembly Instructions

15. Place the previously assembled item #A-1 and panel B as shown. Attach item #A-8 using 2x fastener #13-1 to panel G and attached item #A-8 to item #A-1 using 2x fastener #13-3, finger tighten only. Confirm the gap between item #A-1 and panel G is constant and as minimal as possible as shown below. Fully tighten fasteners.

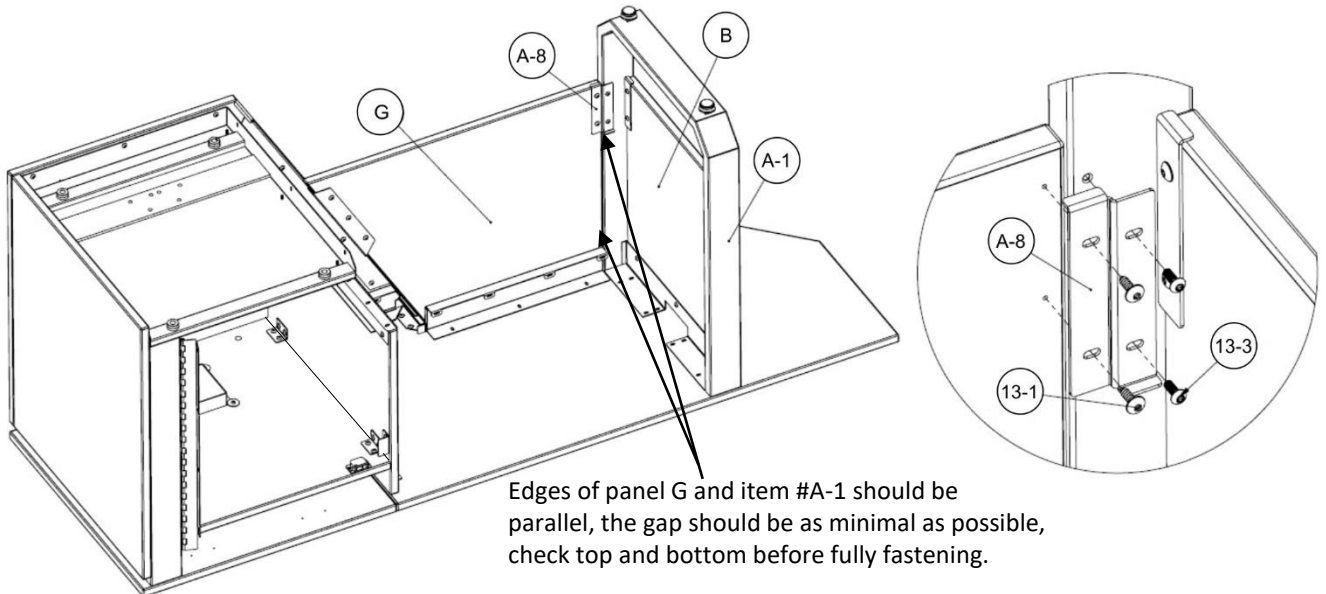

16. Edge of item #A-1 should be parallel with the reference line as shown (depending on the assembly process the reference line may not be flush with the edge of item #A-1) Align edge of tube from item #A-1 with the edge of the wood, NOT the face of the edge banding. Fasten #A-1 to panel U using 8x fastener #13-1 and then fasten item #A-9 to panel T using 3x fastener #13-1.

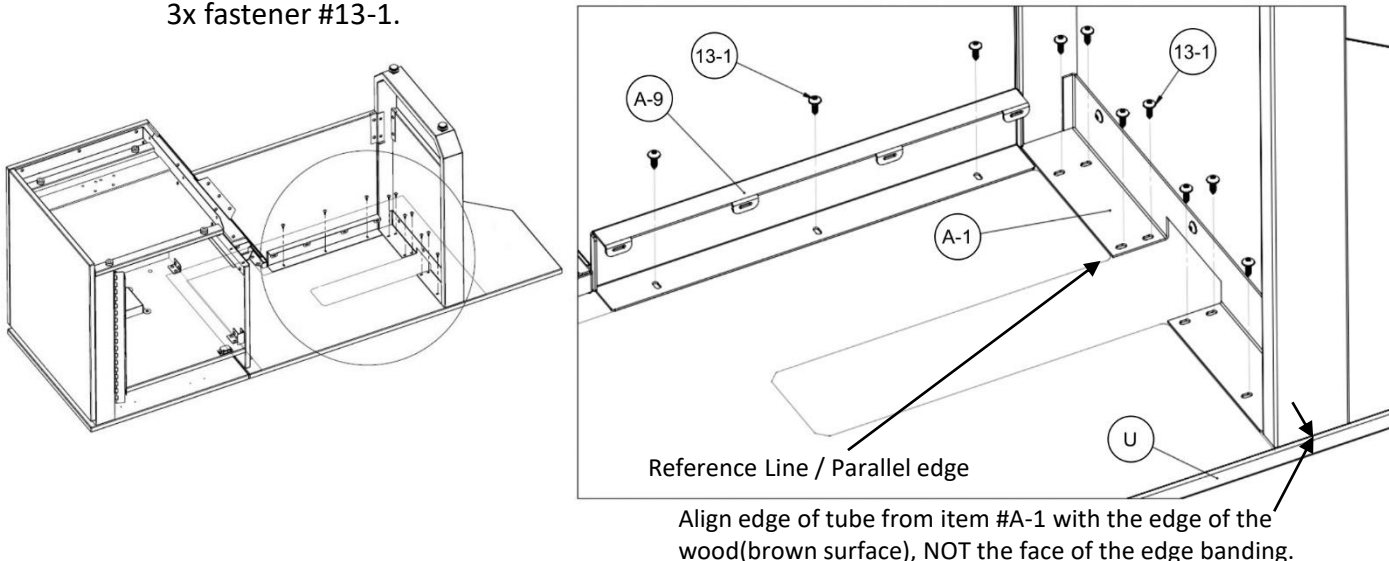

Assembly Instructions

17-A. This step is 72" model only (58022), for 60" model (58020) skip to step 17-B.

Line up item #5 with the reference line. Install 8x fasteners #6 from hardware pack supplied with item #5 into panel U.

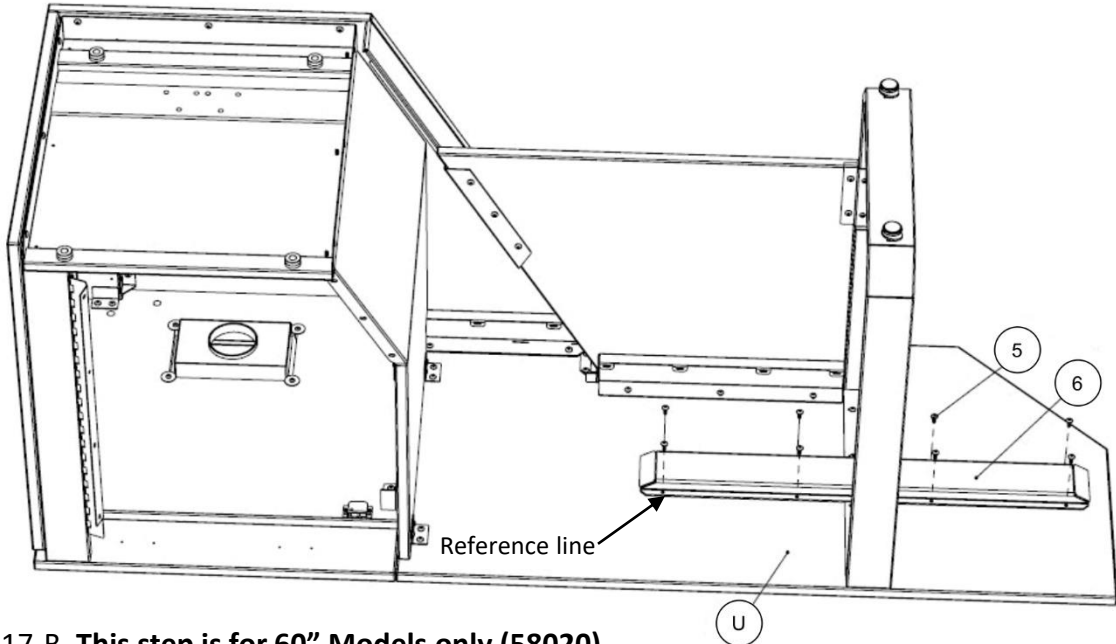

17-B. This step is for 60" Models only (58020).

The indicated face of item #A-10 should be flush as shown. Install 2x fasteners #13-1 into panel J.

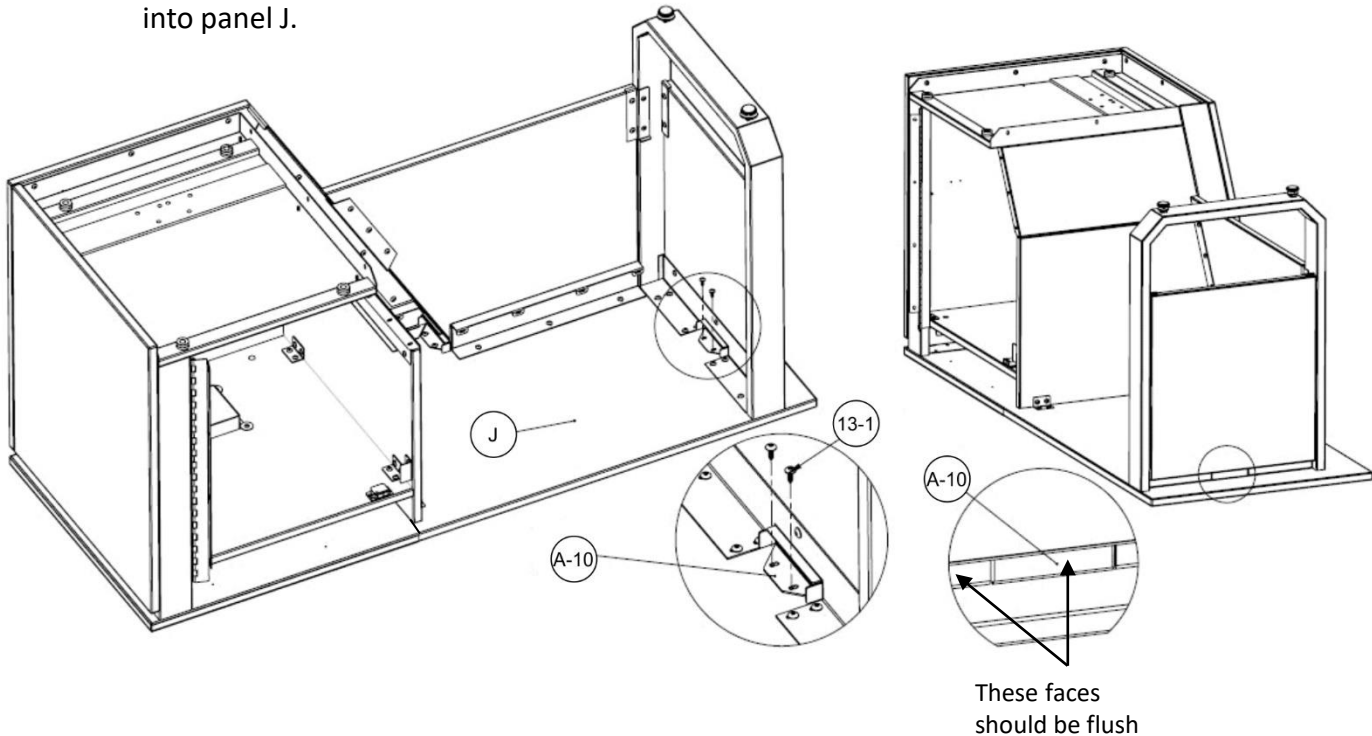

Assembly Instructions

18. Place item #B-10 with the tape face down. Position item #11 as shown below, fasten to item #B-10 using 4x fasteners #11-5 and #11-11

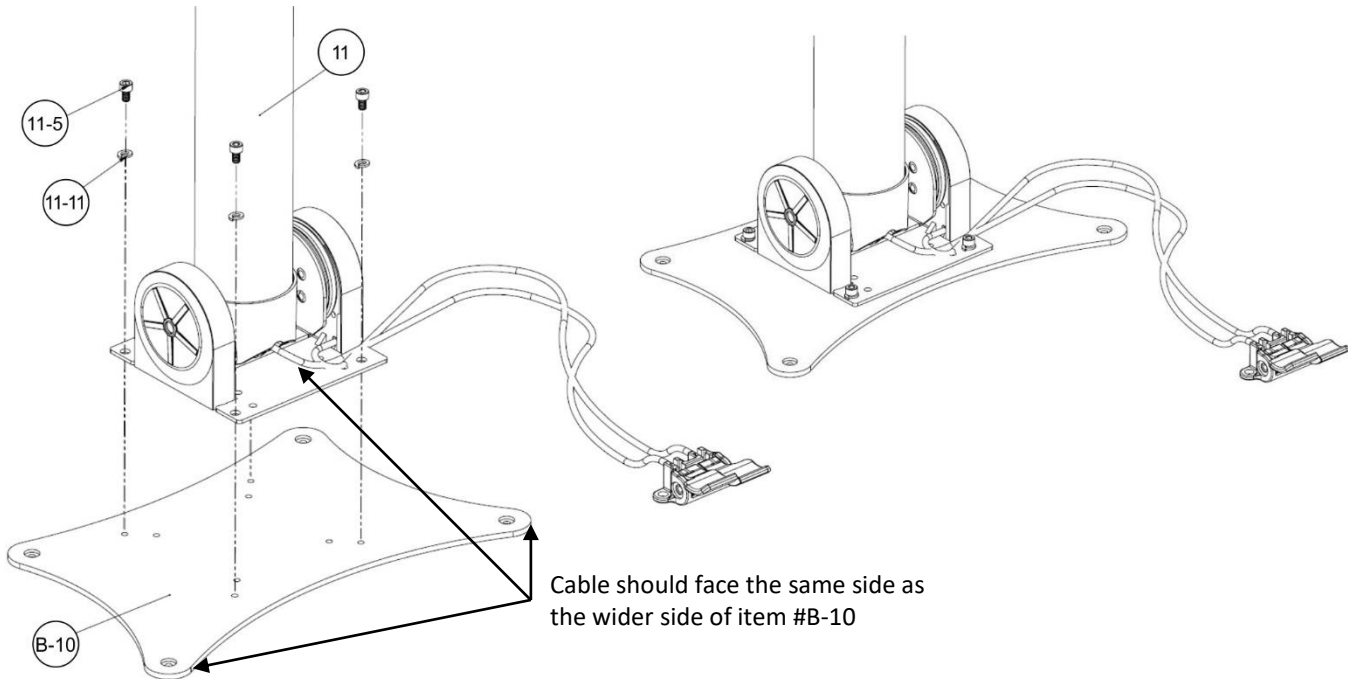

19. Fasten item #B-8 to panel R using 2x fastener #13-1

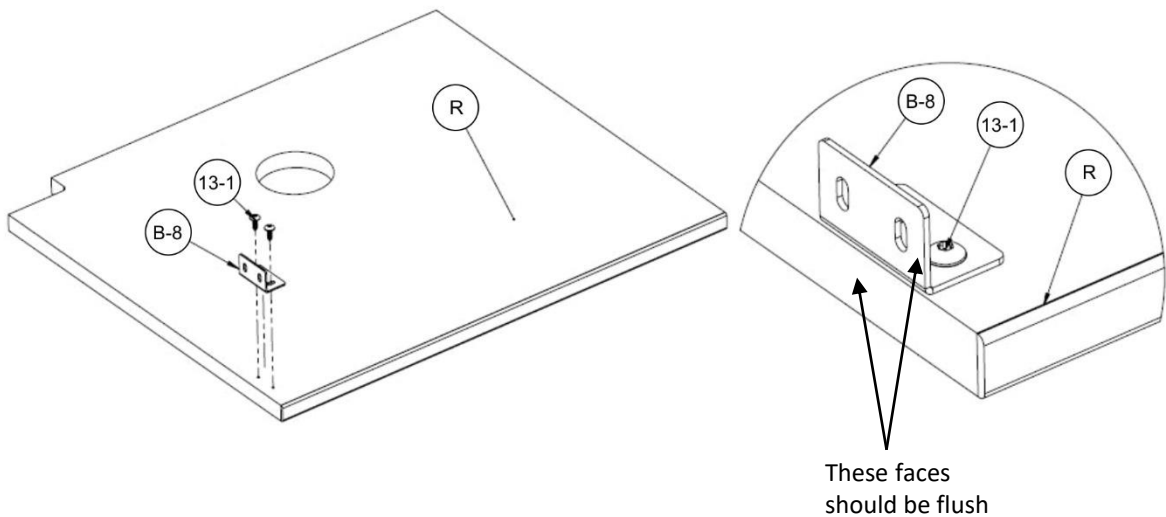

Assembly Instructions

20. On a soft, clean surface flip the desk on its front face as shown. Insert the previously assembled panel R into the unit as shown, fasten panel R with 2x fastener #13-1.

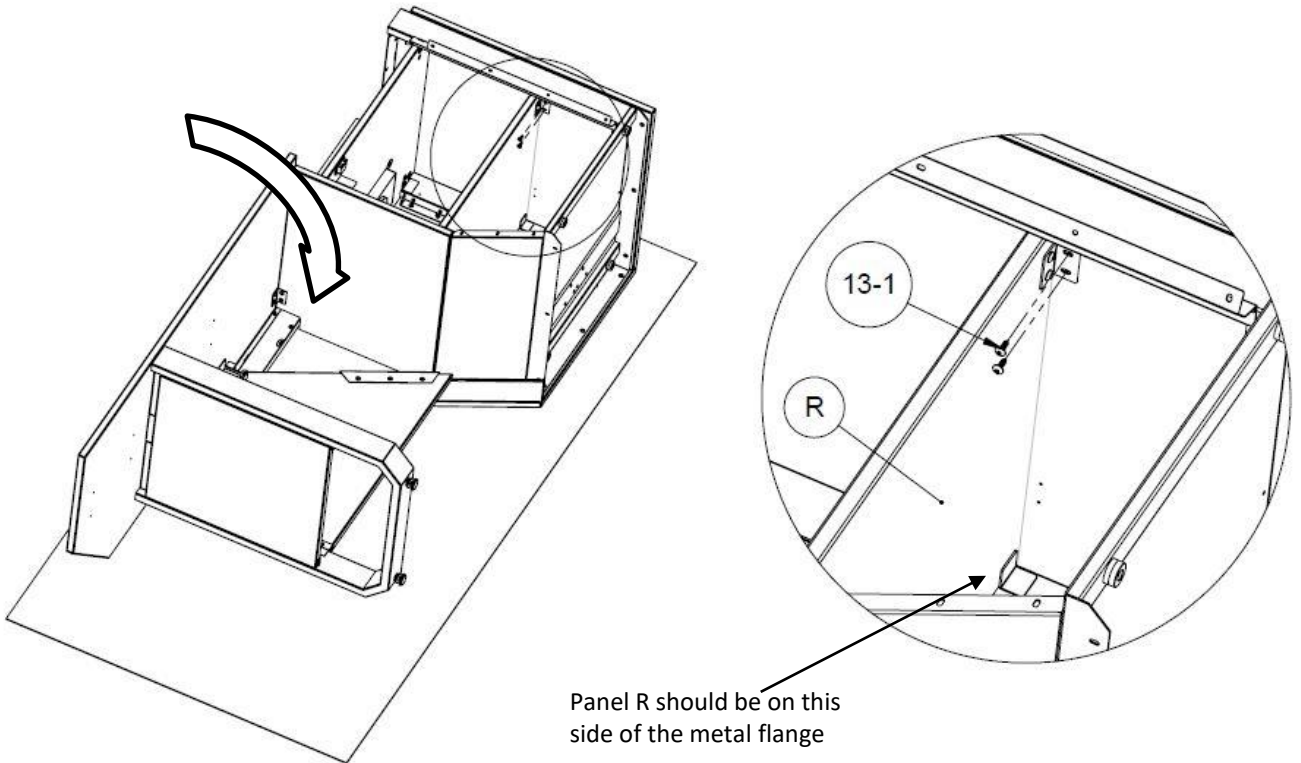

21. Carefully insert the previously assembled item #11 as shown below, the cables should be facing up. Fasten in place using 3x fastener #11-4

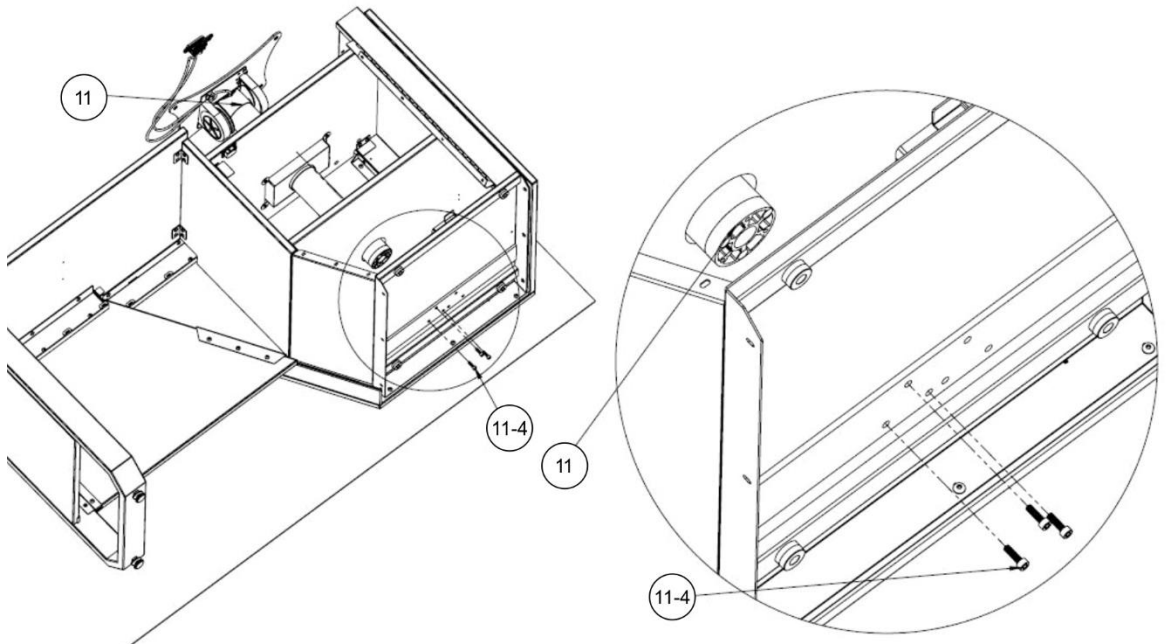

Assembly Instructions

22. Install item #B-6 first as shown below by sliding the tab into the slot of item #A-11. Slide over to lock into place. Repeat step for item #B-3. Slide item #B-6 back to touch item #B-3.

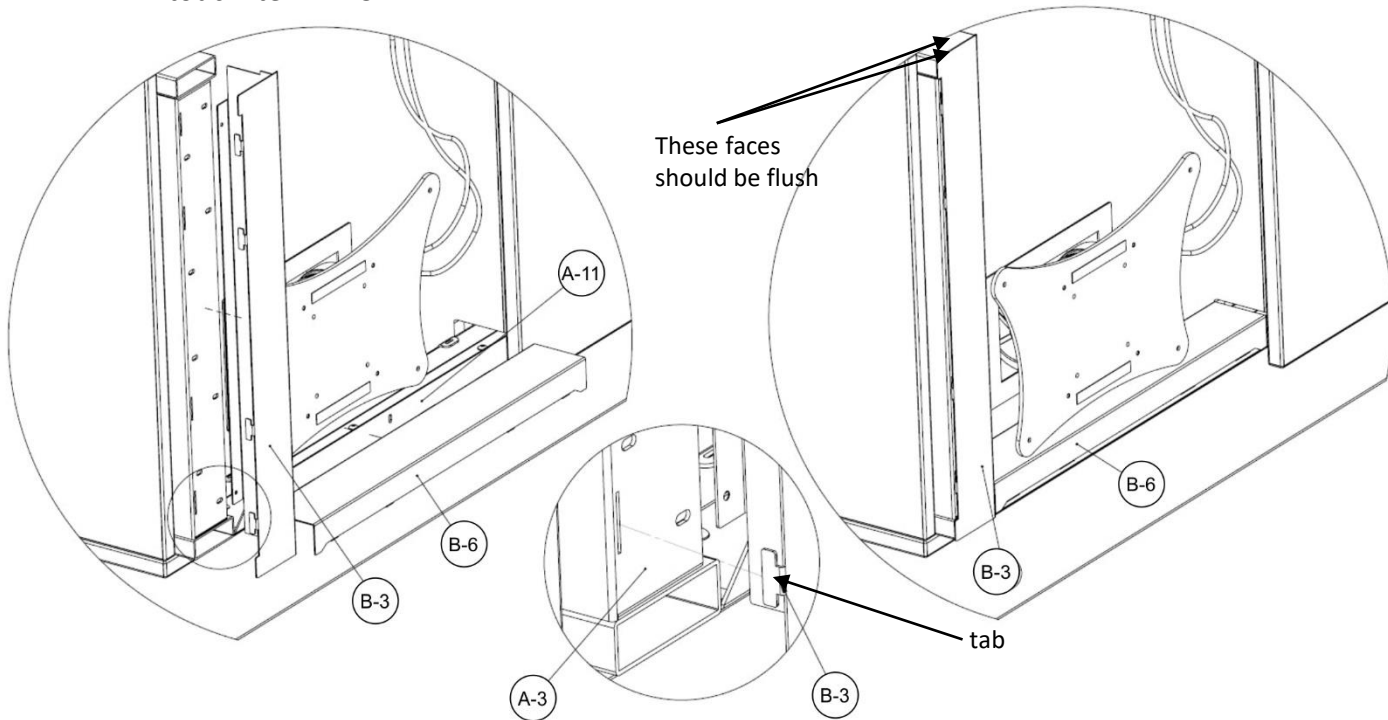

23. Install 4x of fastener #11-10 and #11-9 as shown, fastening items #B-3 and #B-6 in place.

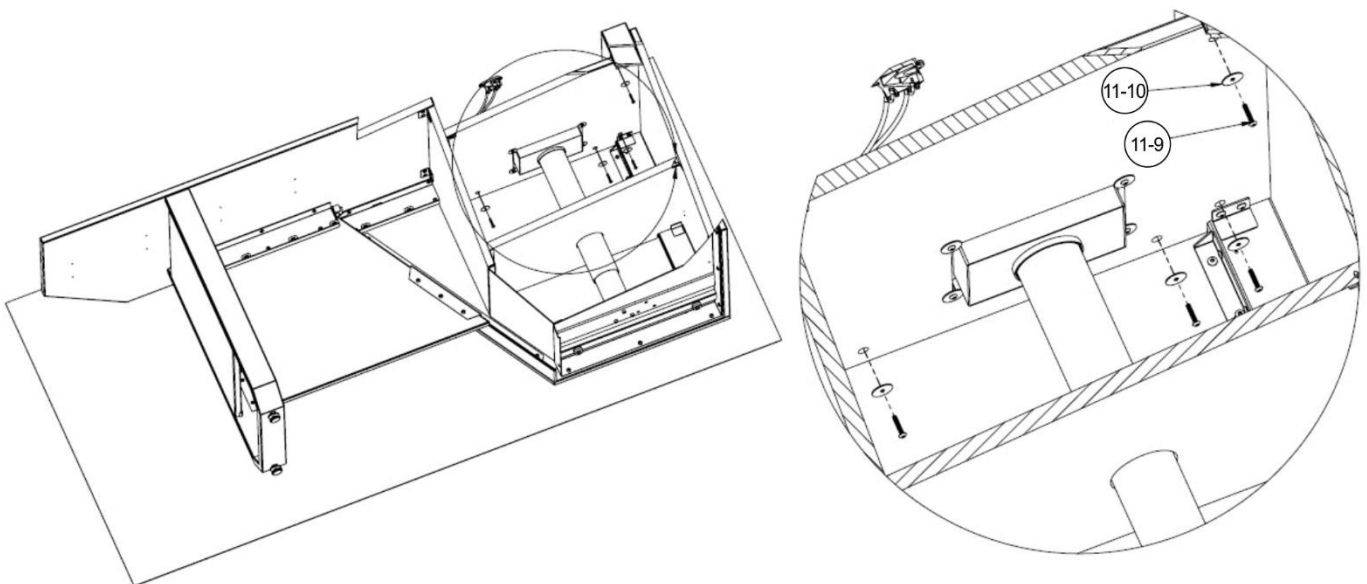

Assembly Instructions

24. Install item #7, #8, #9 and #10 as shown below.

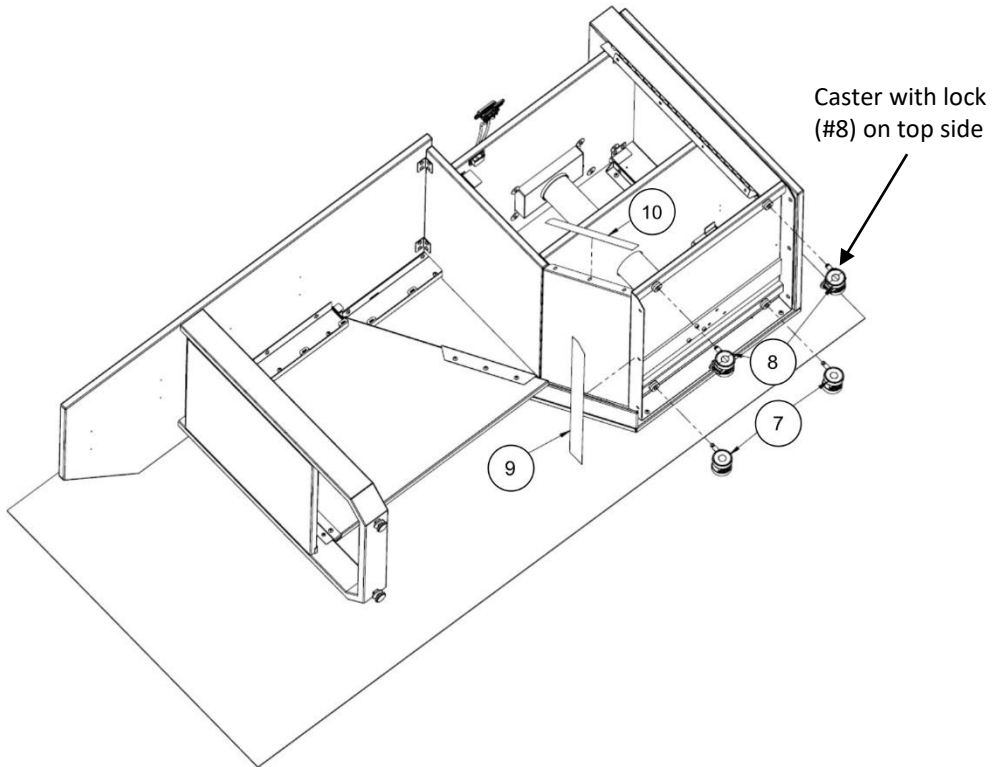

25. Carefully flip table to stand upright, without removing the tape backing, place panel K on top of item #B-10. While pressing the right lever, push down on panel K until it makes contact with the top of item #B-3. Release the right lever and remove panel K. Remove tape backing and replace panel K, leaving a small, credit card width, gap between panels K and U. Press panel K firmly in place.

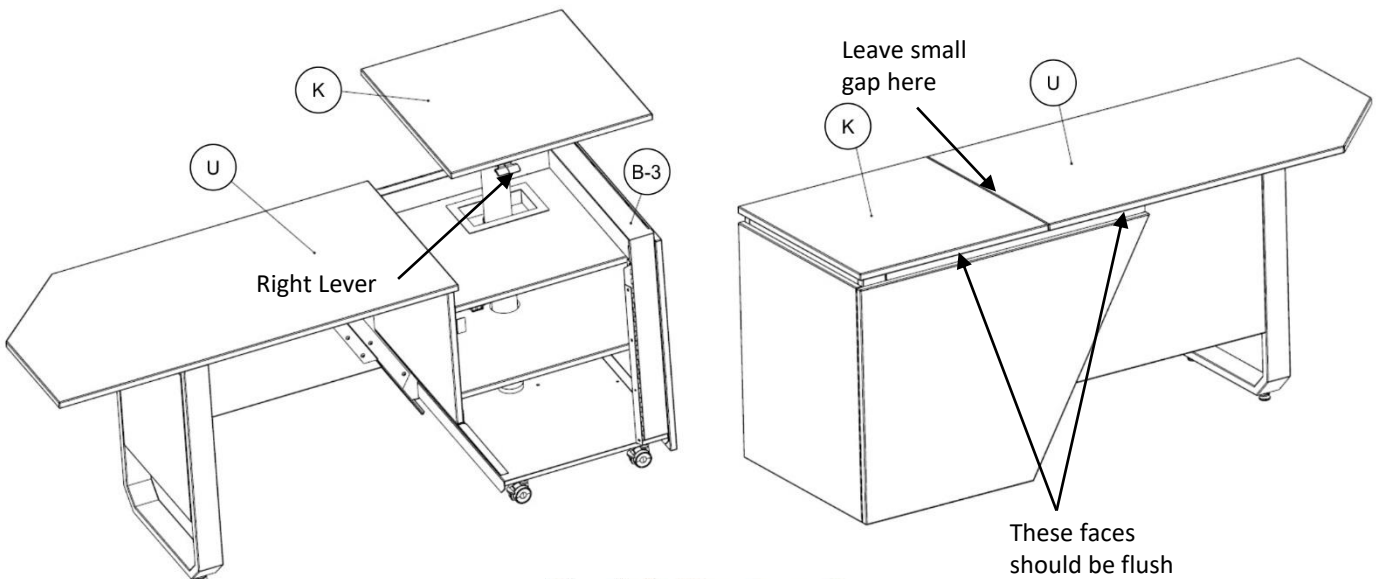

Assembly Instructions

26. While applying pressure to panel K, press right lever to raise lift mechanism fully. Using 4x fastener #13-1, attach top K as shown while applying pressure from above.

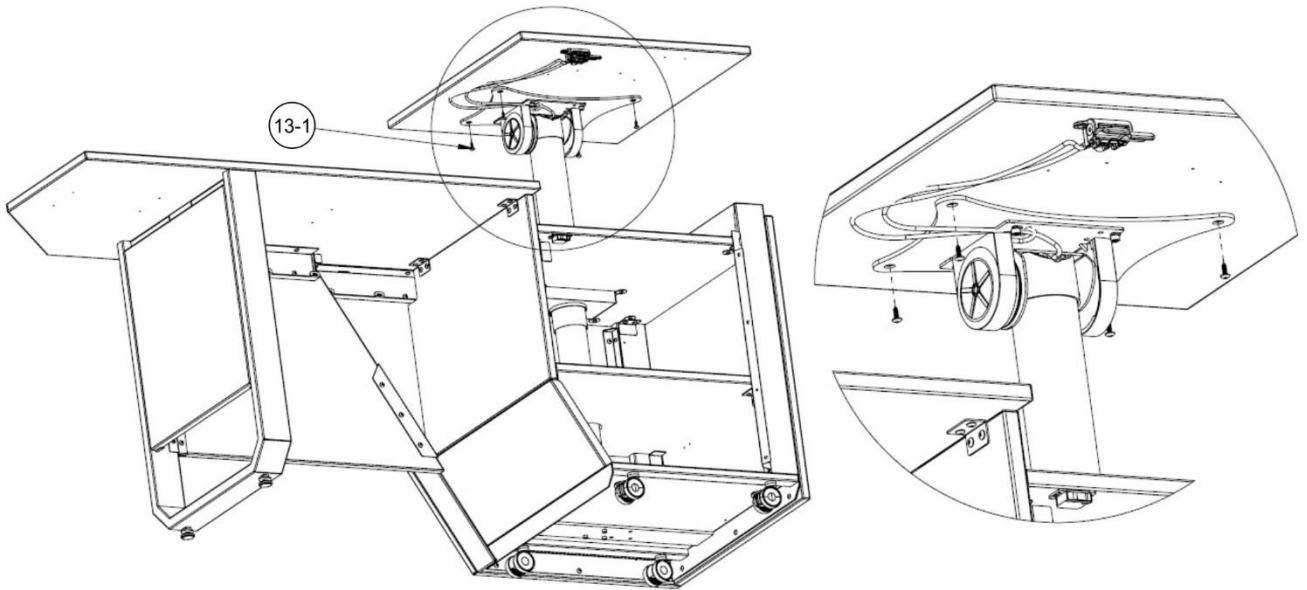

27. Attach lift the lever and item #11-6 with 4x fastener #13-1 choosing your left- or right- hand operation. Confirm the lift operates freely, then tighten the 4x fasteners #11-3 from step 6

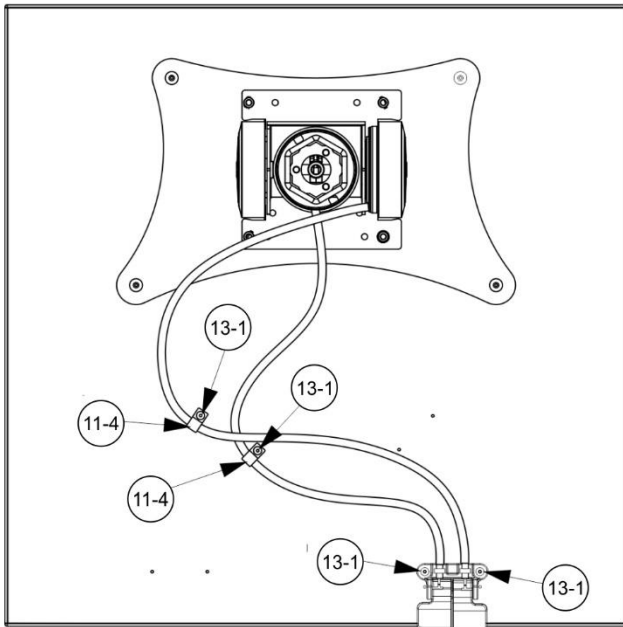

For Operation With Left Hand

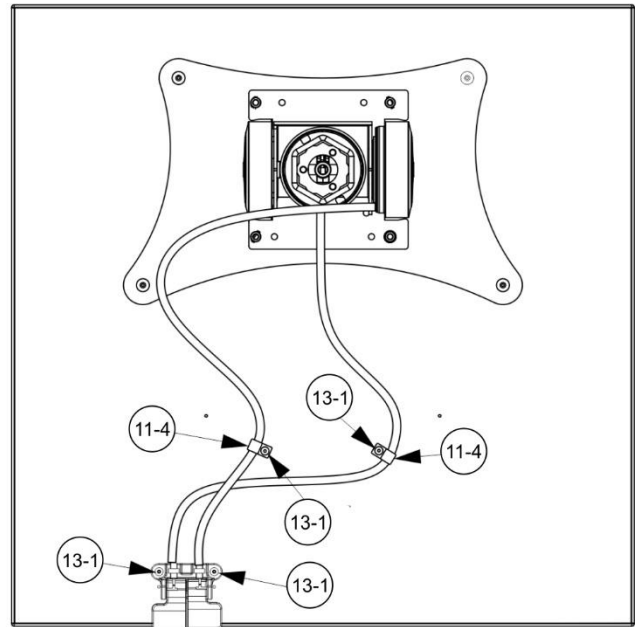

For Operation With Right Hand

Assembly Instructions

28. Assemble door lock item #B-5 as shown with the gray laminate side facing up. Install item #2 using 2x fastener #3.

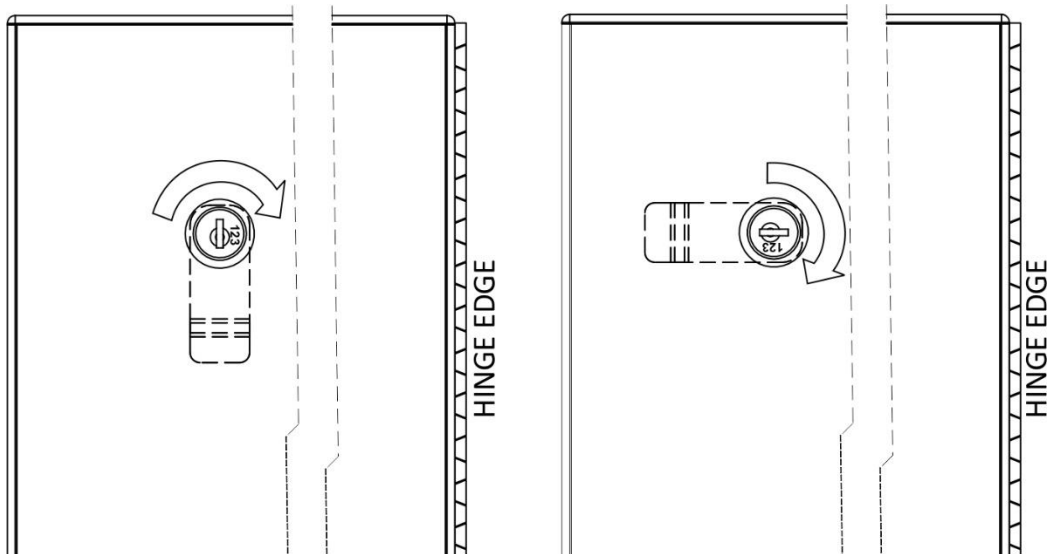
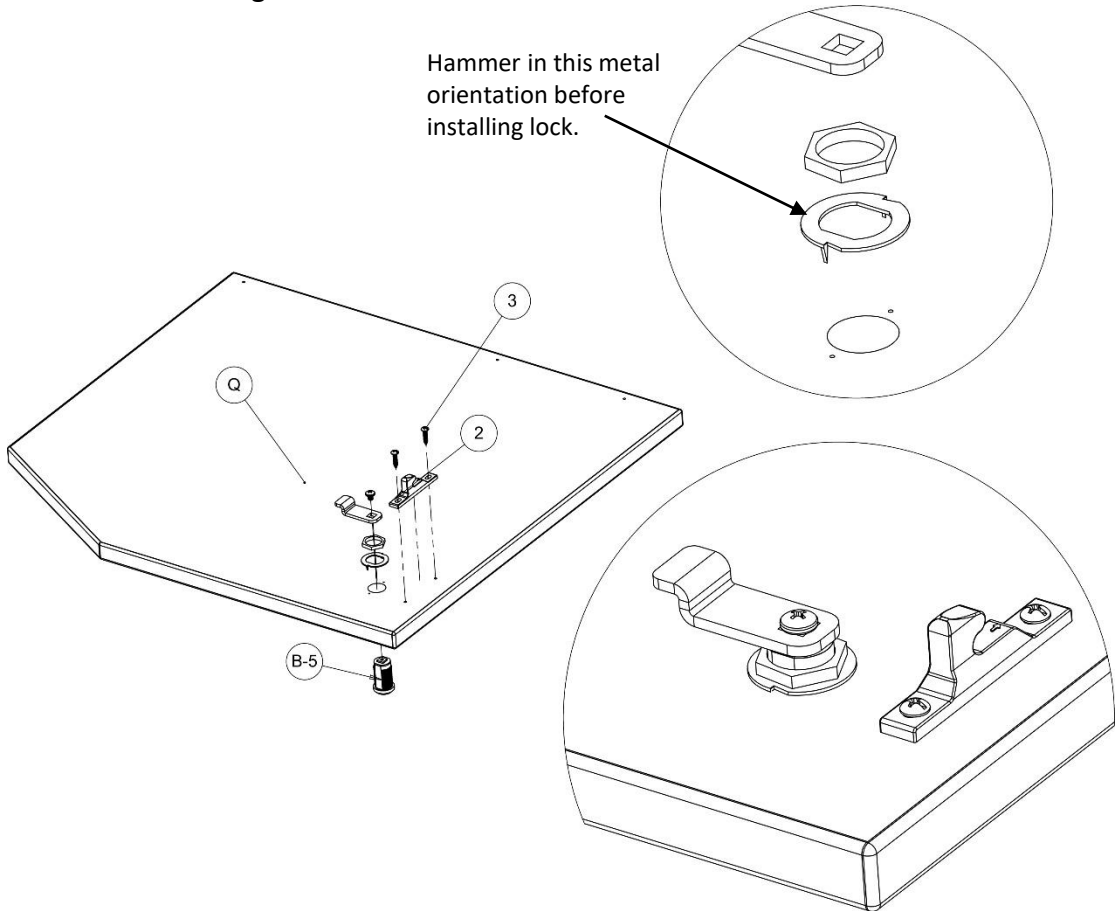

Assembly Instructions

29. Place previously assembled panel Q as shown, installing indicated 3x fastener #13-1 first. Confirm the door hangs level, latches, and locks correctly. Lock the door location in place by installing 1x fastener #13-1 in panel Q and 1x fastener #11-2 in the inside of the unit.
30. Remove adhesive backing from pencil/paper retainer #A-15. Align front edges of #A-15 and top K and press firmly to attach.

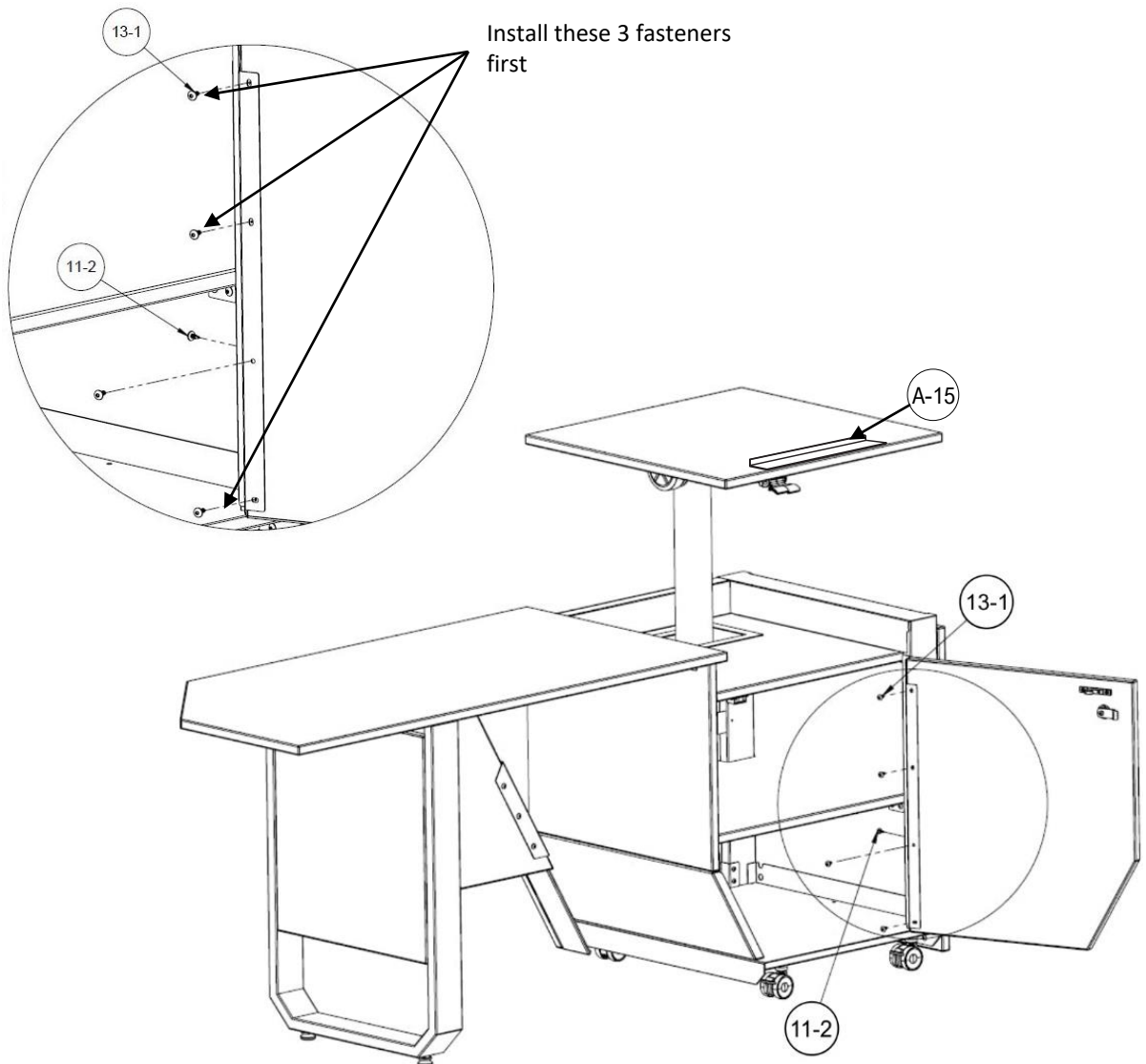

Assembly Complete.