

Assembly Instructions

Secondary Surface on Flowform Round Triangle Table



If you have damaged or missing components,
please contact customer service at 1-800-328-1061

Hardware and Components

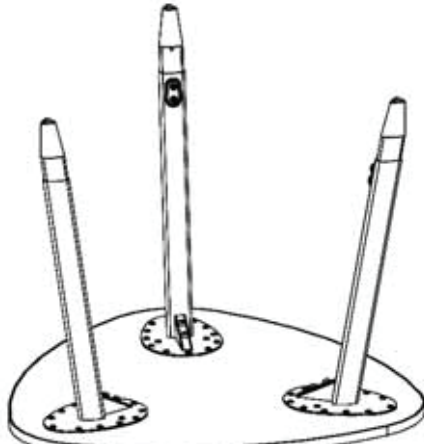

ROUND TRIANGLE TABLE WITH LEGS
INSTALLED
QTY. 1

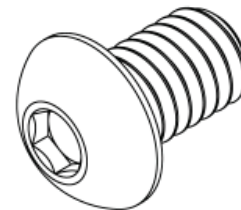

5/16" -18 X 1/2" BOLT
(ALREADY INSTALLED ON LEG)
QTY. 6



SECONDARY SURFACE PLATE
(PN: 60013)
QTY. 1

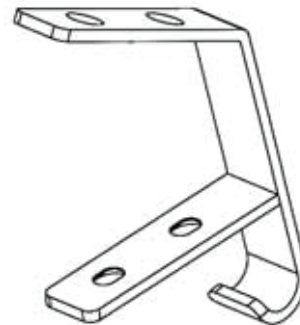

SECONDARY SURFACE BRACKET
(PN: 60013)
QTY. 3



#10-32 X 1/4" UNDERCUT FLAT-HEAD SCREW
QTY. 6

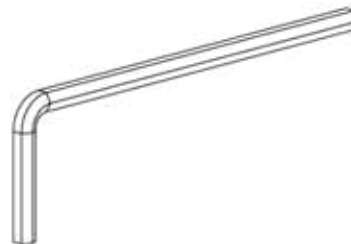

1/8" ALLEN WRENCH
QTY. 1

Special Notes:

- TOOLS REQUIRED:
 - 3/16" Allen wrench (included with legs) or 3/16" Allen drill bit.
- Check that all components are accounted for and undamaged before assembling.
- Please assemble the product in a clean and dry area.
- Clean the product with a mild cleaner and a damp cloth.

Assembly Instructions

1. After assembling the legs to the top and leaving it on a clean smooth surface that will not harm the top finish, remove the 5/16"-18 x 1/2" Bolts and set to the side.

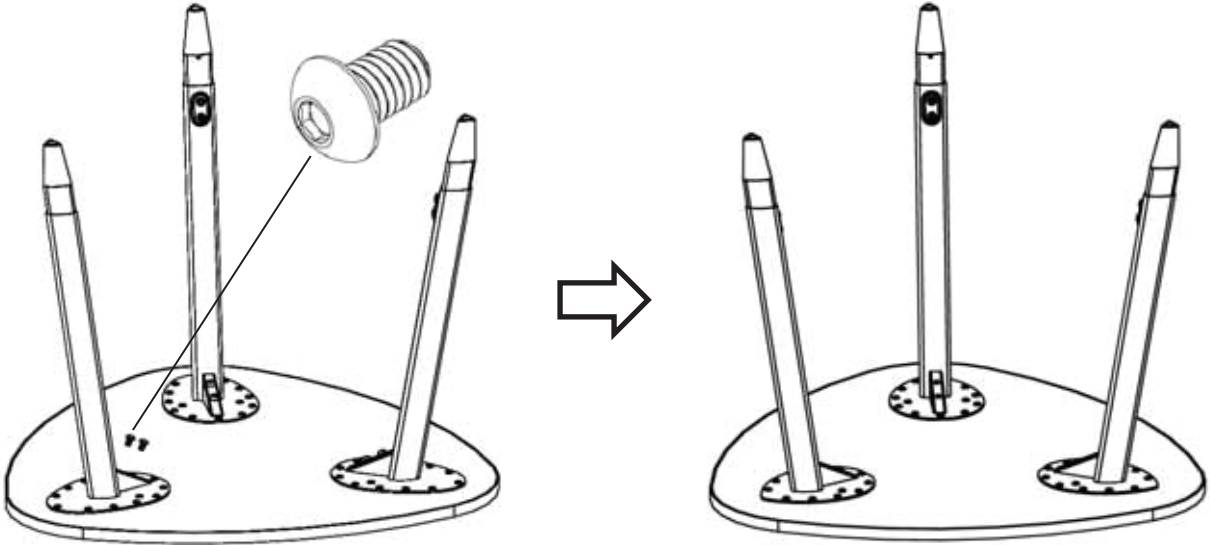

2. Lay secondary surface plate down on a clean smooth surface that will not harm the plate finish. Underside of plate should be exposed.

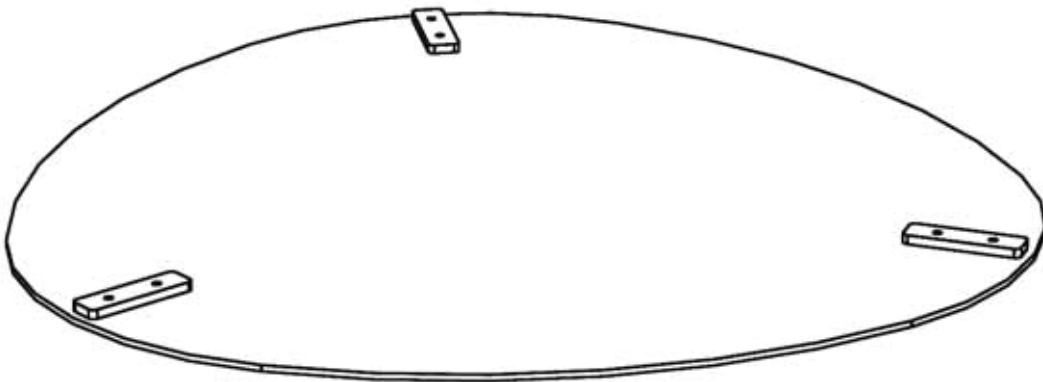

3. Attach the bracket using two of the #10-32 x 1/4" Undercut Flat-Head Screws, but do not fully tighten it yet.

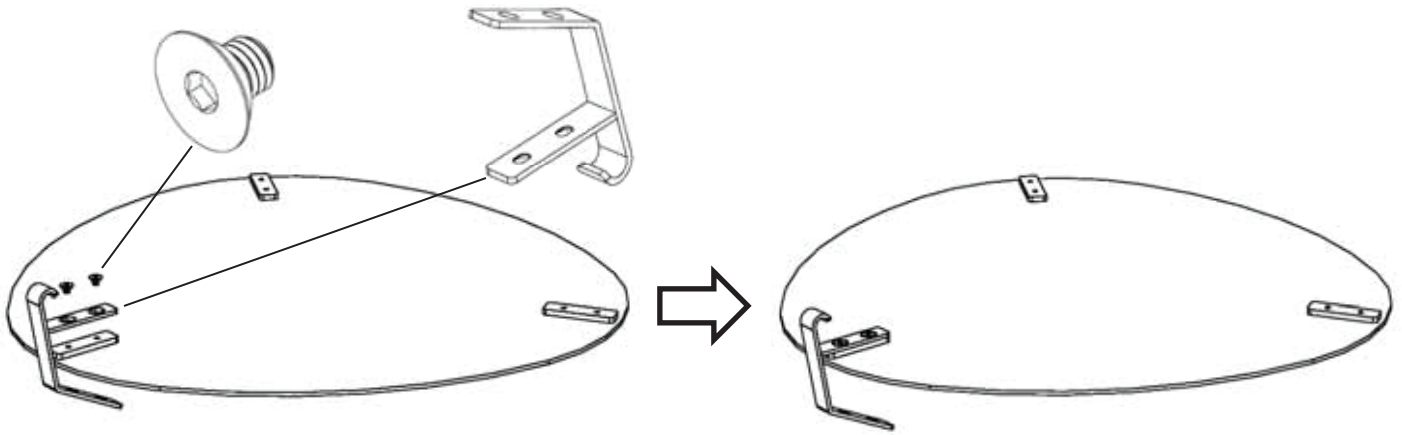

4. Attach the other two brackets leaving them loose for positioning.

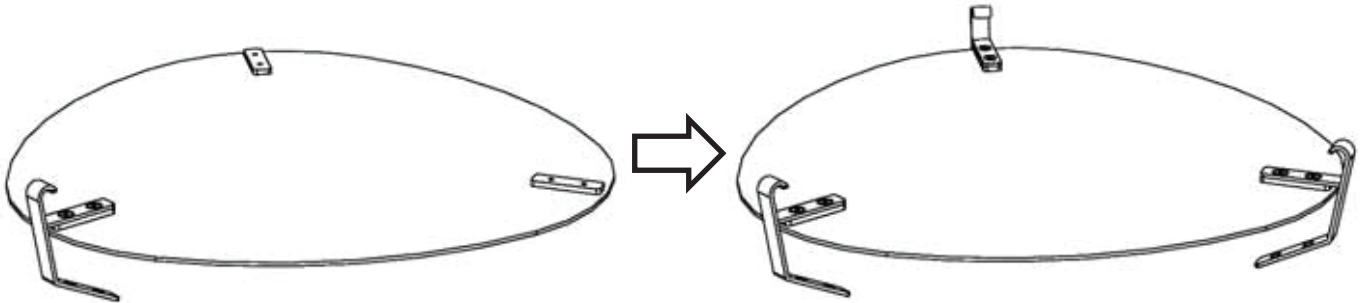

5. Place plate in the center of the legs on the table aligning the brackets with the gussets on the legs.

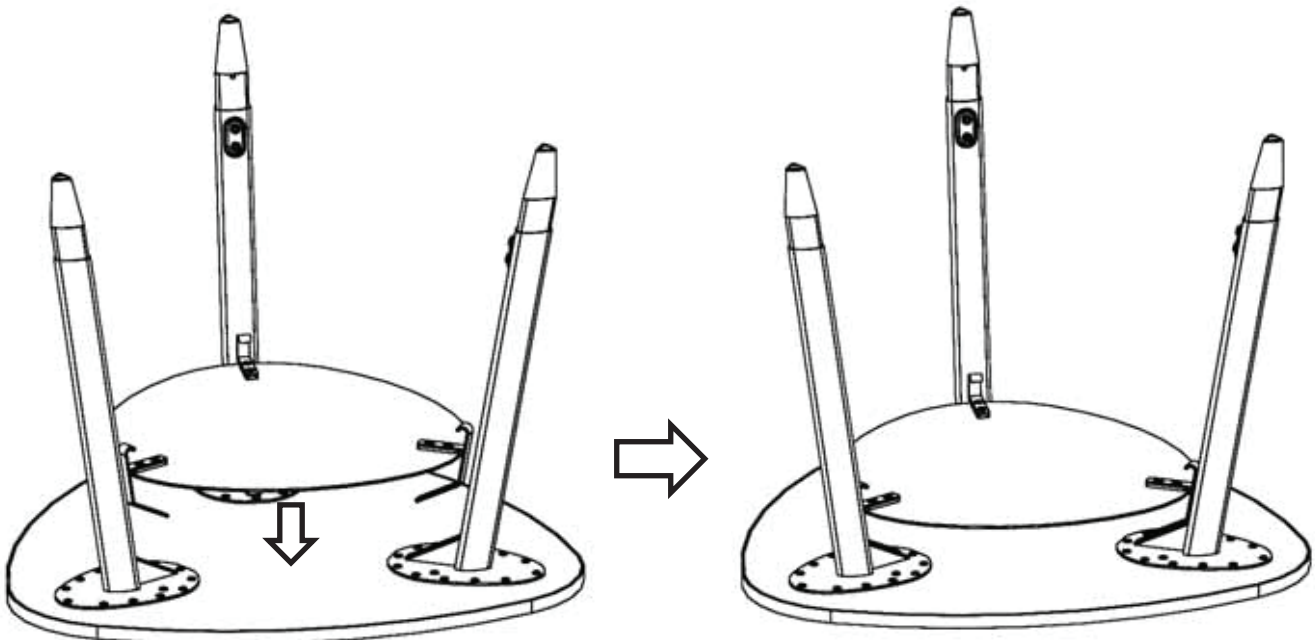

6. Install two of the 5/16"-18 x 1/2" Bolts into the bracket and the leg gusset. Repeat for the other brackets. Now tighten all screws.

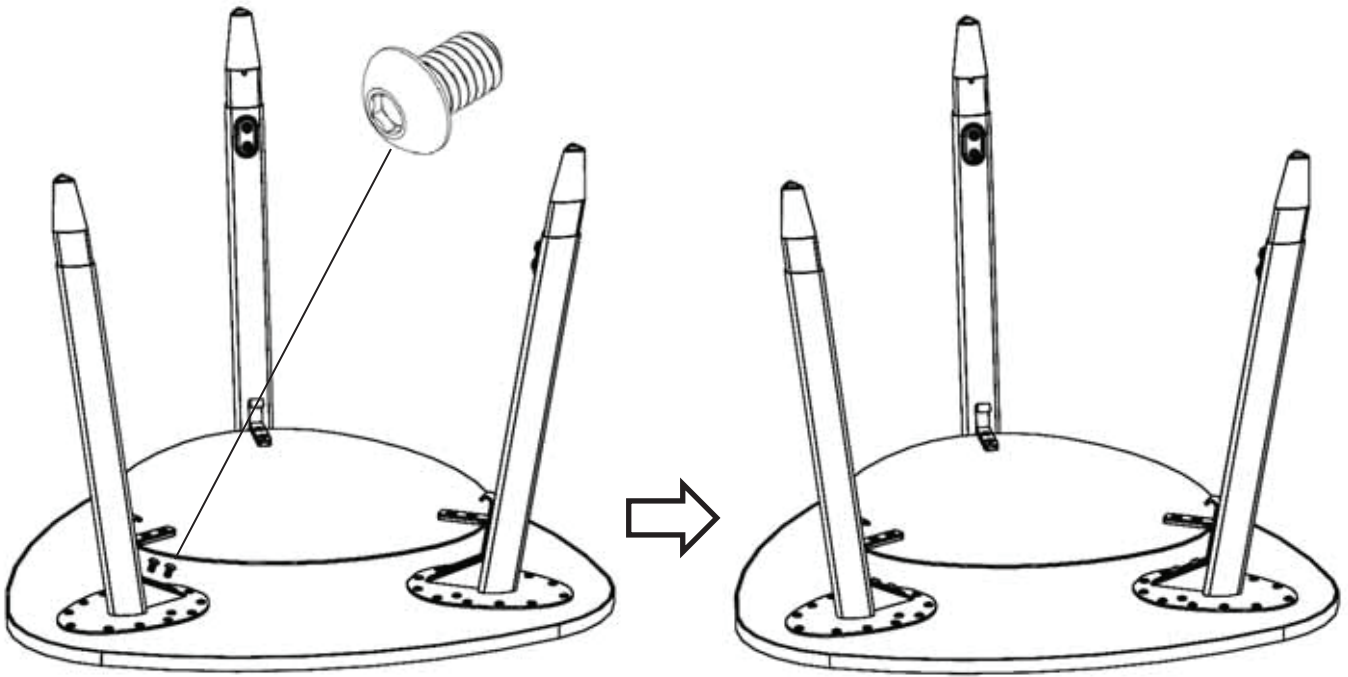

7. Flip table over.

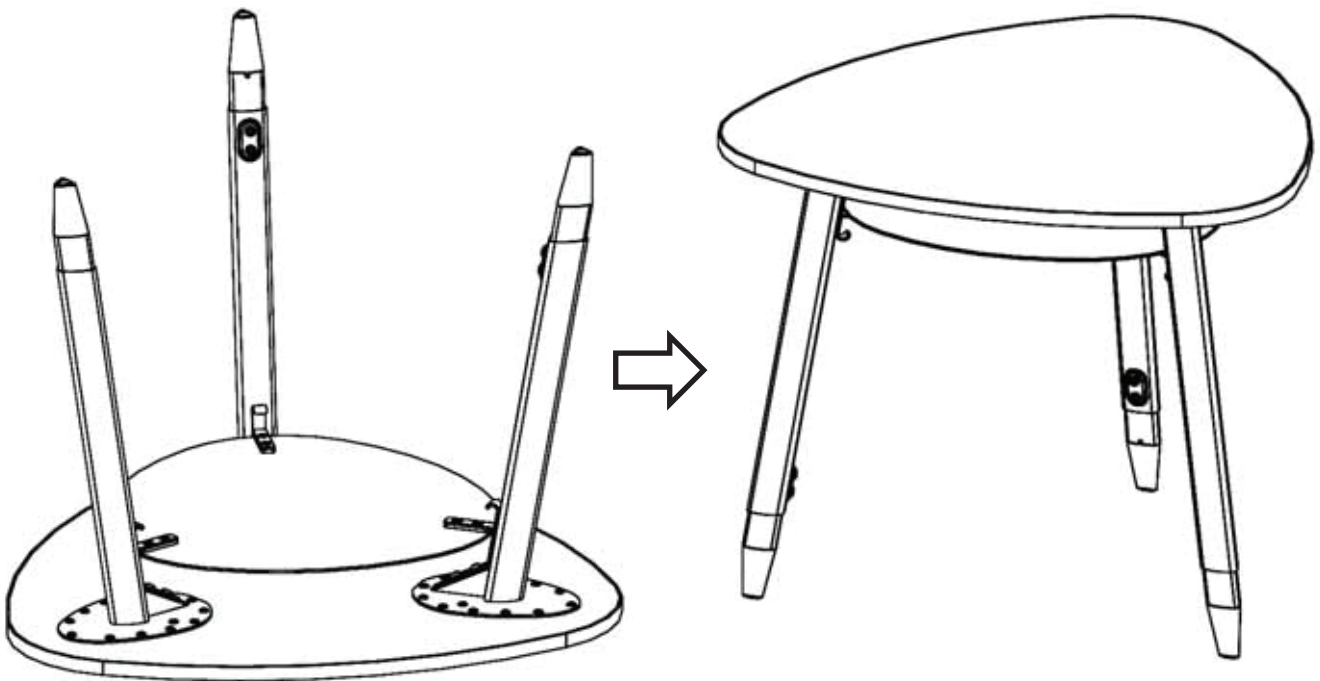

ASSEMBLY COMPLETE