

Assembly Instructions

NUMBERS DESKS

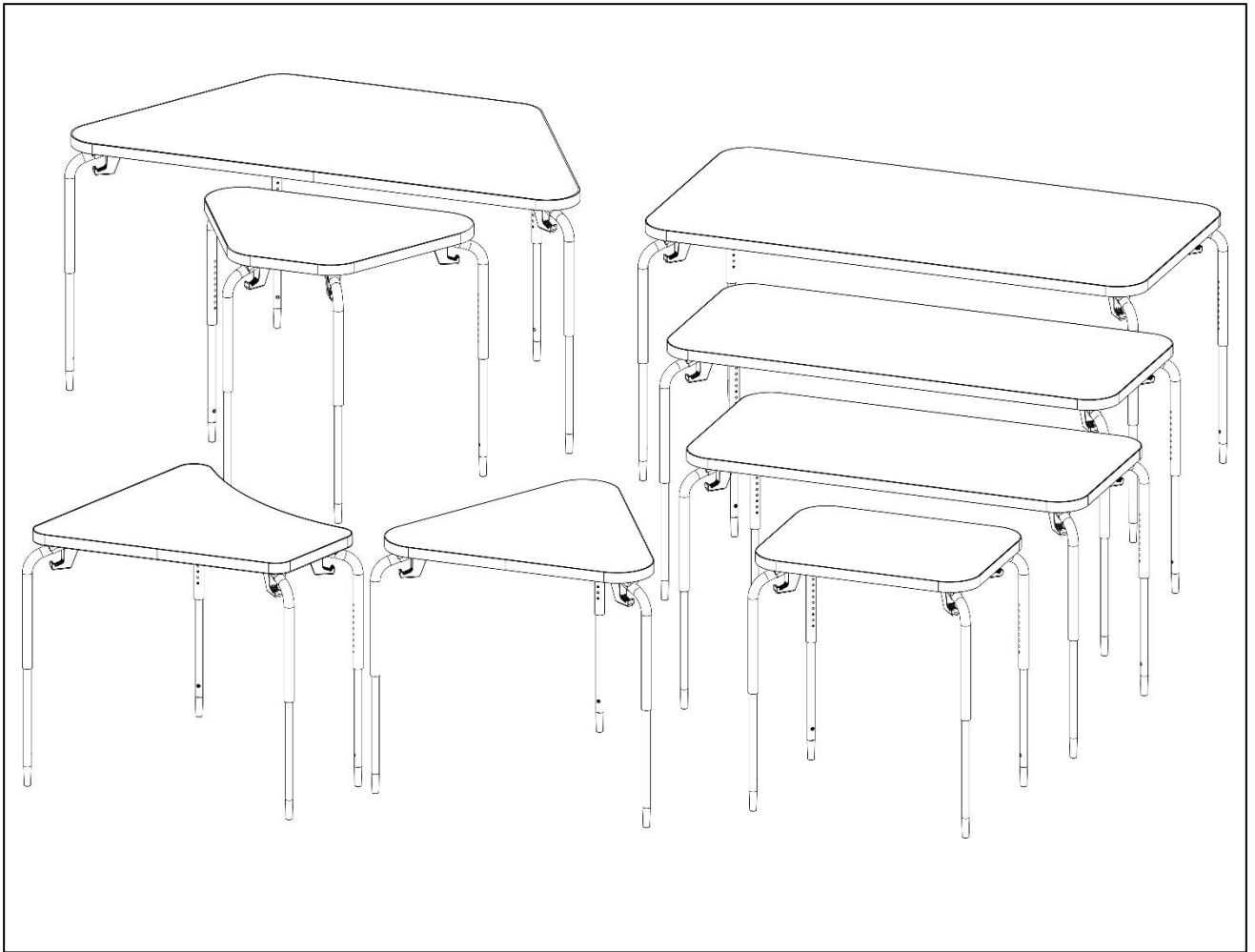

MODEL NUMBERS

02130, 02131, 02132, 02133, 02140, 02141,
02142, 02143

If you have damaged or missing components,
please contact customer service at 1-800-328-1061

Hardware and Components

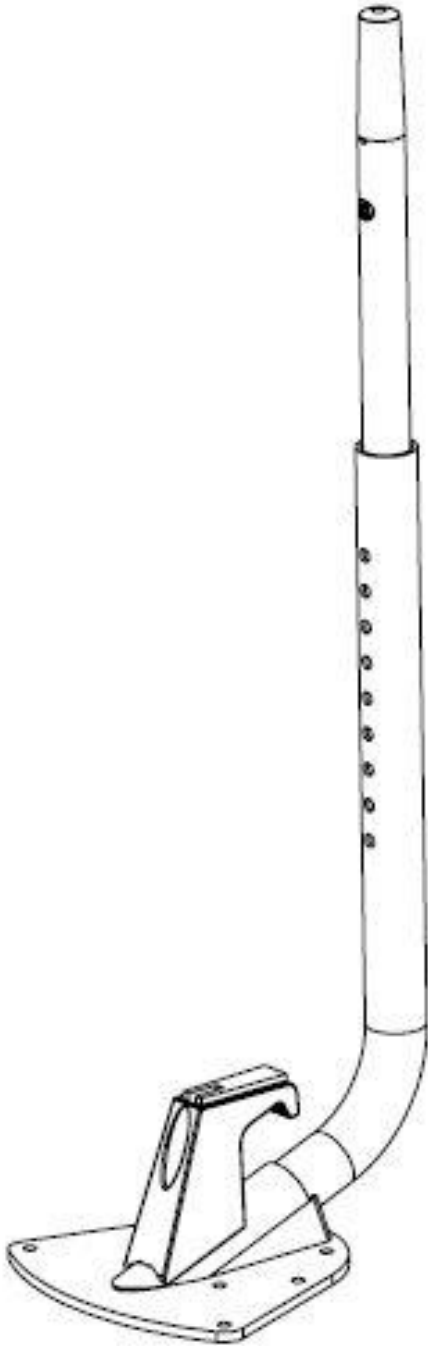

NUMBERS SINGLE LEG ASSEMBLY
QTY. 3 OR 4



NO. 10X1-1/8" TORX BUTTON HEAD SCREW
QTY. 8 PER LEG ASSEMBLY

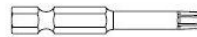

T25 TORX POWER BIT 2"
QTY. 1



NUMBERS DESK LEG CUSTOM SET SCREW
3/8-16 X 3/4"
QTY. 2 PER INSERT



1/8" ALLEN KEY
QTY. 1

OPTIONAL ACCESSORIES



LOW RANGE INSERT
QTY. 3 OR 4

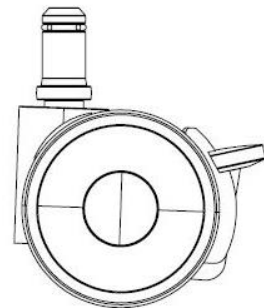

2" LOCKABLE CASTER
QTY. 3 OR 4

Special Notes:

- Check that all components are accounted for and undamaged before assembling.
- Please assemble the product in a clean and dry area.
- Clean the product with a mild cleaner and a damp cloth.

Assembly Instructions

1. Place wood top on clean smooth surface upside down with the pilot holes facing up. Align holes in the single legs with the pilot holes. Using the included T25 torx bit fasten all single leg assemblies using 8x NO. 10X1-1/8" torx button head screws per leg.

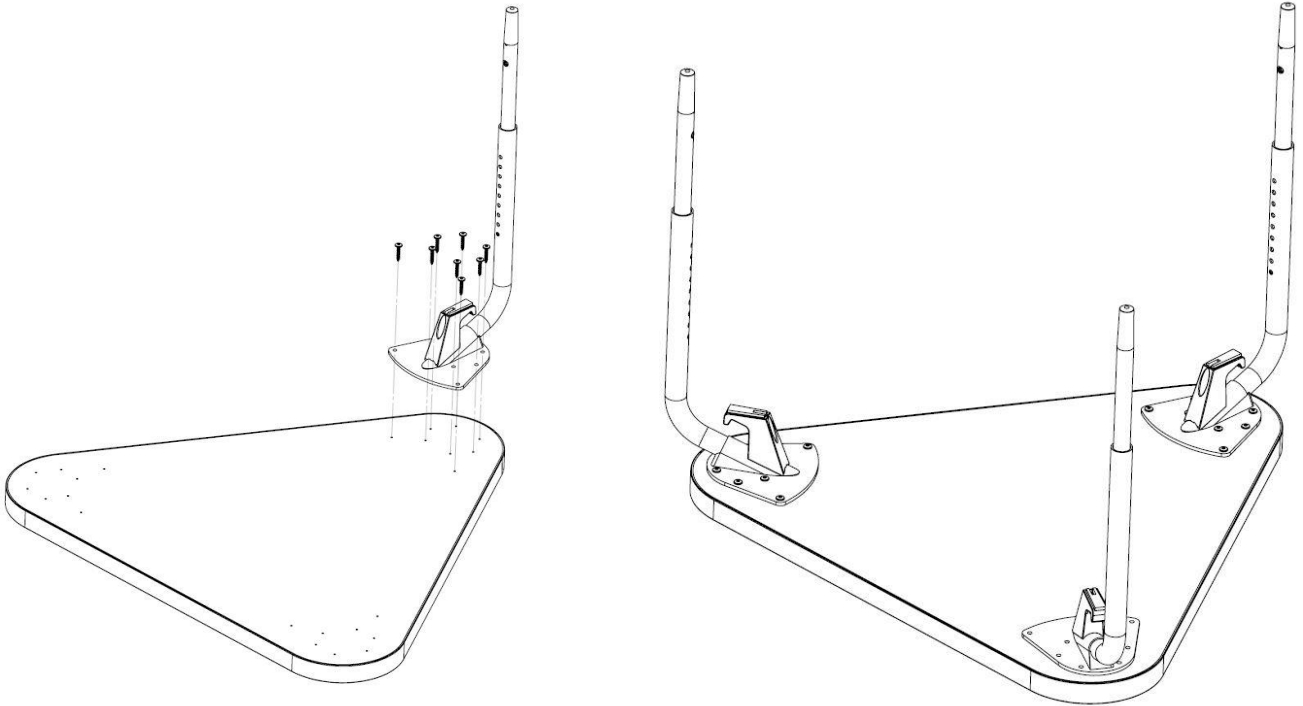

2. To adjust the table height, use the supplied 1/8" Allen Key, the numbers leg sets uses a hidden fastener to adjust the legs. This set screw can be access through adjustment holes as shown below. Turn the set screw clockwise to loosen and counterclockwise to tighten the inserts in place. The set screw will fit inside the adjustment hole to set the table height.

The set screw will fit inside the adjustment hole to set the table height.

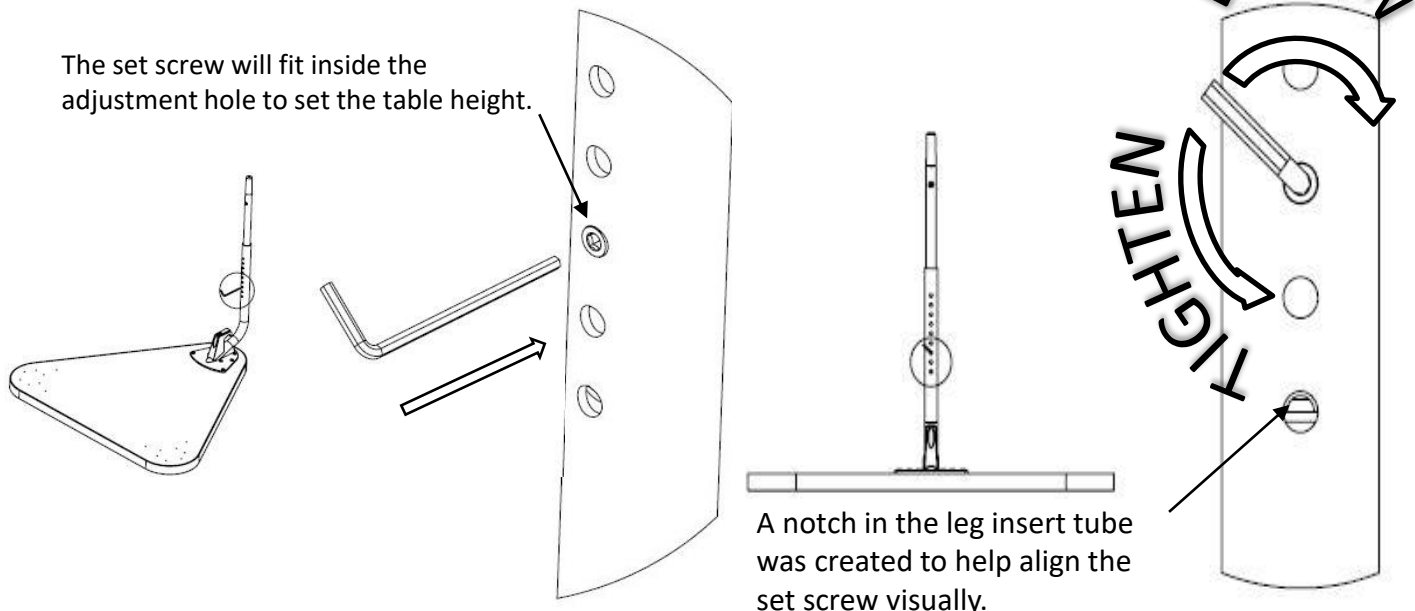

A notch in the leg insert tube was created to help align the set screw visually.

Assembly Instructions

3. To change the leg set to the optional glide version, turn the set screw clockwise until it stops, remove the leg insert and rotate 180 degrees inserting the glided side of the leg set into the tube first. Follow step 2 to set the leg height and tighten the insert into place. Install press in caster as shown.

