

Assembly Instructions

Planner Studio

Adjustable Height Tables

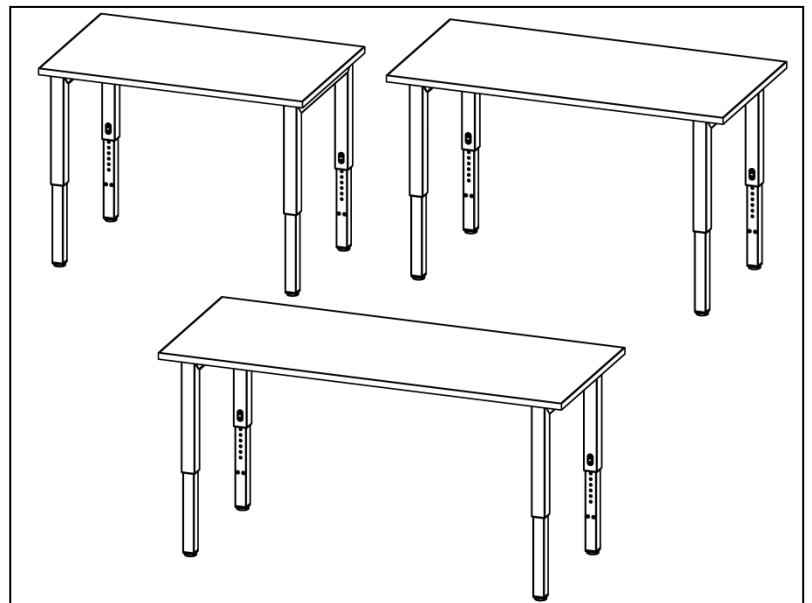
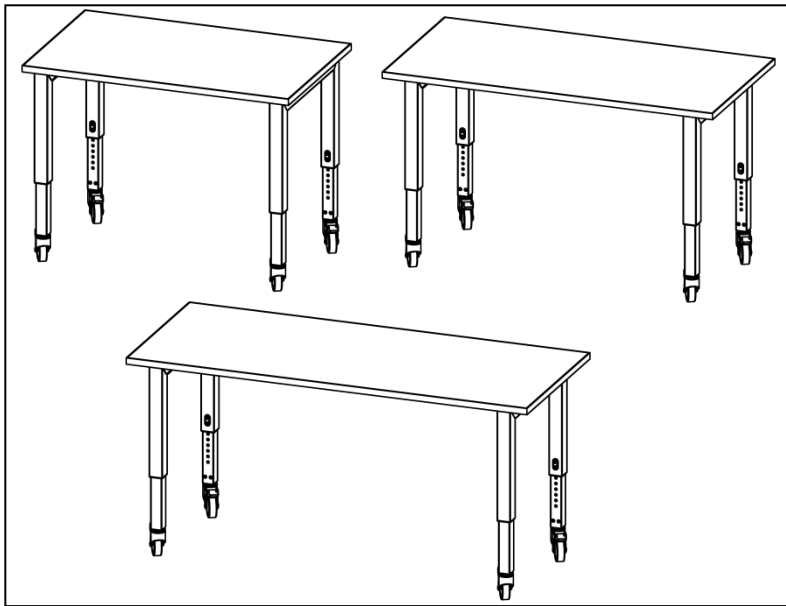

If you have damaged or missing components,
please contact customer service at 1-800-328-1061

Hardware and Components

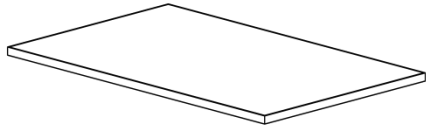

PLANNER STUDIO TOP
QTY. 1

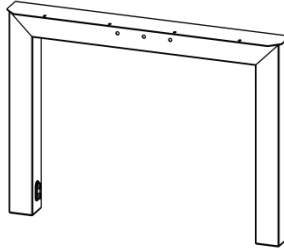

PLANNER STUDIO LEG BASE
QTY. 2

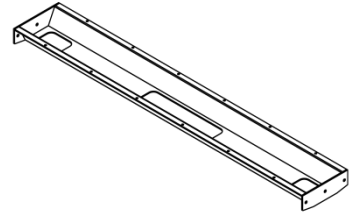

PLANNER STUDIO SUPPORT CHANNEL
QTY. 1

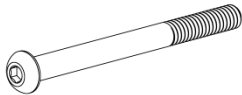

1/4\"-20 X 3\" BOLT
QTY. 6



1/4\"-20 LOCK NUT
QTY. 6

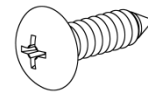

#10 X 3/4\" WOOD SCREW
QTY. 28



3/8\"-16 X 5/8\" SET SCREW
QTY. 8

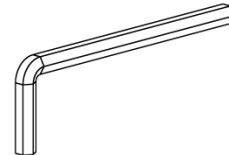

3/16\" ALLEN WRENCH
QTY. 1

PACK #70008
(LOW RANGE: #77239)

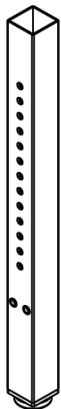

**PLANNER STUDIO ADJUSTABLE
LEG WITH GLIDES**
QTY. 4

PACK #70009
(LOW RANGE: #77240)

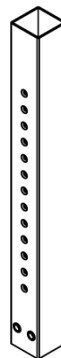

**PLANNER STUDIO ADJUSTABLE
LEG FOR CASTERS**
QTY. 4

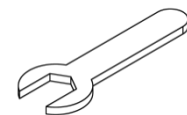

CASTER WRENCH
QTY. 1

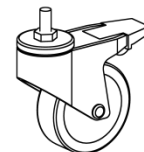

4\" CASTER
QTY. 4

Special Notes:

- TOOLS REQUIRED:
 - Drill w/#2 phillips driver bit, or #2 phillips head screwdriver.
 - 7/16" socket & ratchet, or 7/16" wrench.
- Check that all components are accounted for and undamaged before assembling.
- Please assemble the product in a clean and dry area.
- You will need another person to help assemble the product. Team lifting required.
- Clean the product with a mild cleaner and a damp cloth.

Assembly Instructions

1. Lay top down on a clean smooth surface that will not harm the top finish. Underside of top should be exposed. **Top is heavy, team lifting is advised.**

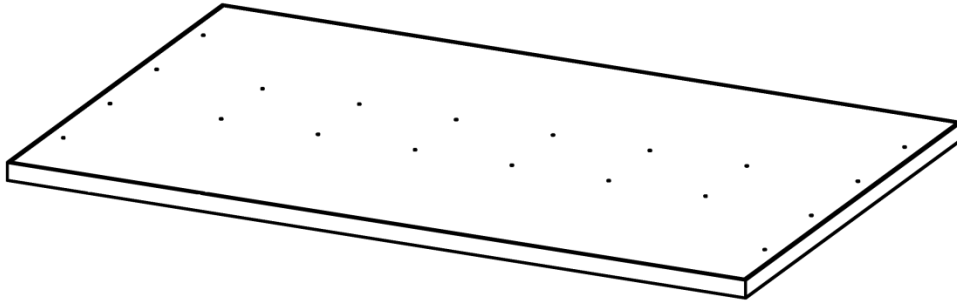

2. Position the support channel(s) onto the top, as shown. Do not attach support channel to top yet. First attach the legs, one at a time, to the support channel(s) by using the supplied 1/4"-20 x 3" bolts and 1/4"-20 lock nuts.

Helpful Hint: The nut goes on the inside; bolt head seen on the outside.

Helpful Hint: Make sure legs are facing the right direction, as shown.

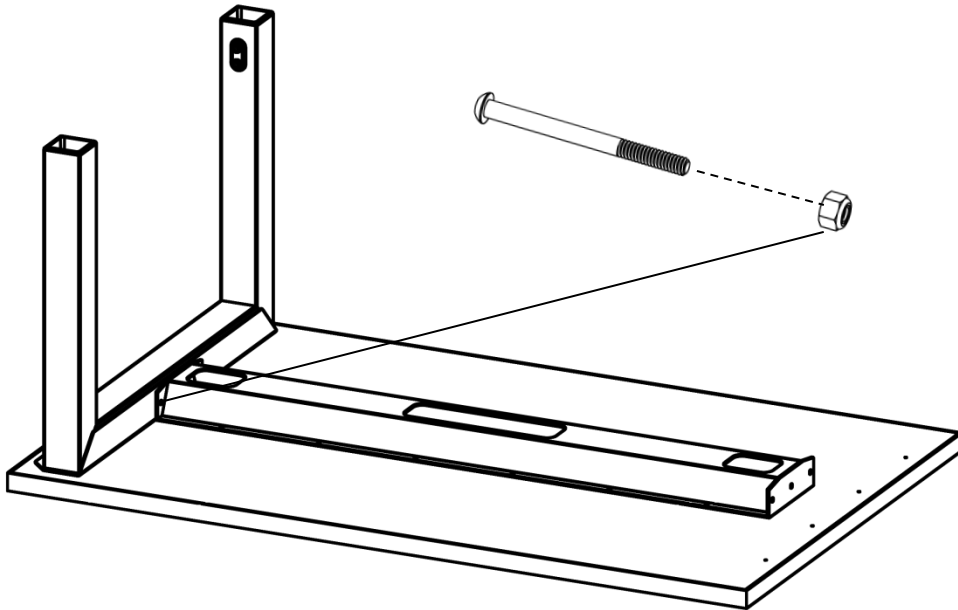

3. Attach the now assembled frame to the wood top using #10 x 3/4" wood screws. Hole pattern on underside of top serves as a guide for proper positioning.

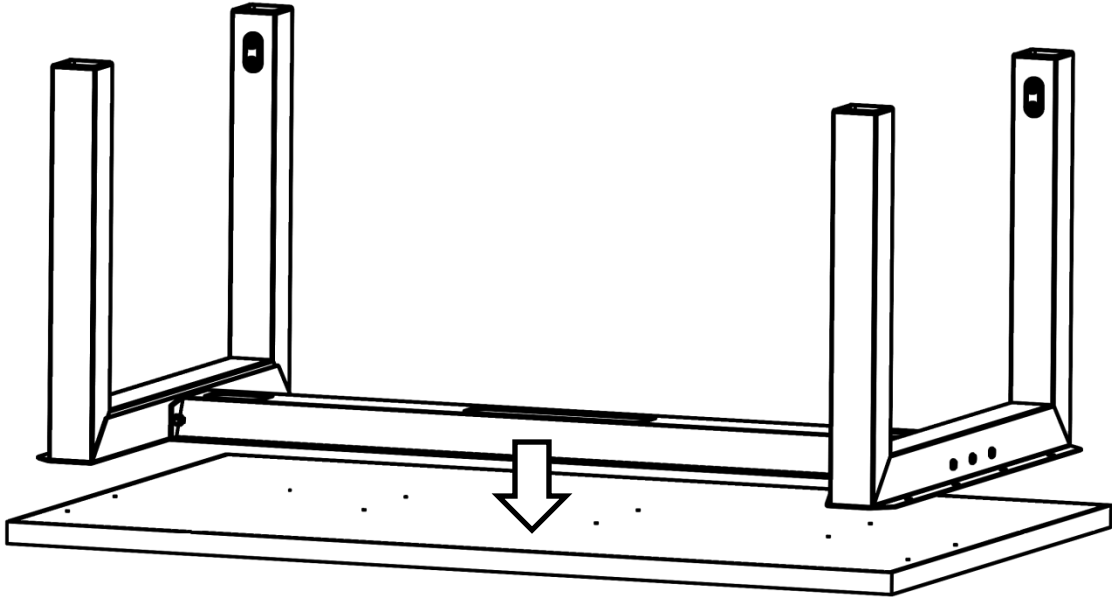

4. **CASTER / GLIDE INSTALLATION**

- a. **GLIDES** - Install adjustable legs into leg base, place at desired height and then lock in place using 3/8"-16 x 5/8" set screws.

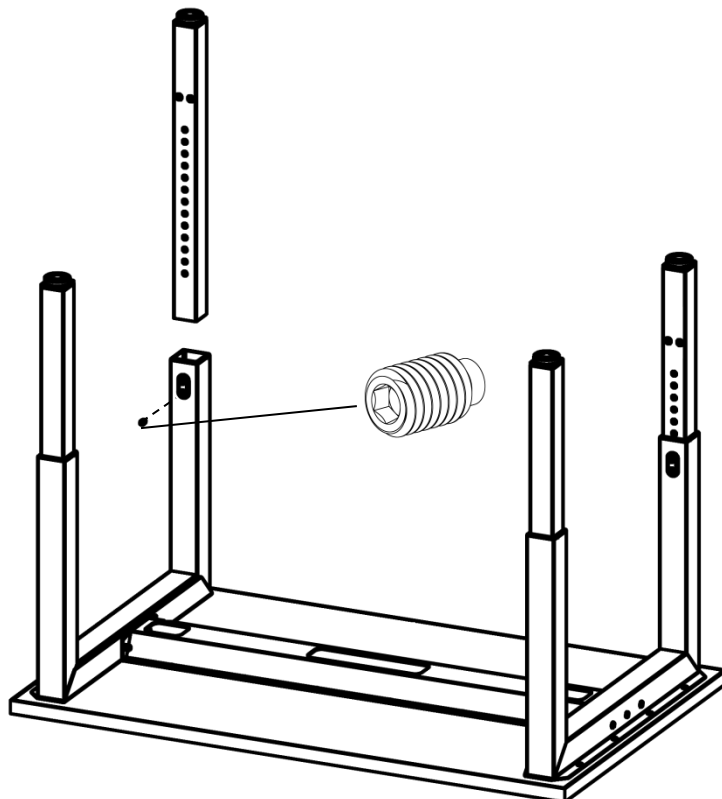

4. CASTER / GLIDE INSTALLATION (continued)

b. **CASTERS - Step 1:** Install adjustable legs into leg base, place at desired height and then lock in place using 3/8" -16 x 5/8" set screws.

CASTERS - Step 2: Install casters using the caster wrench provided. Hand tighten until very snug.

STEP 1

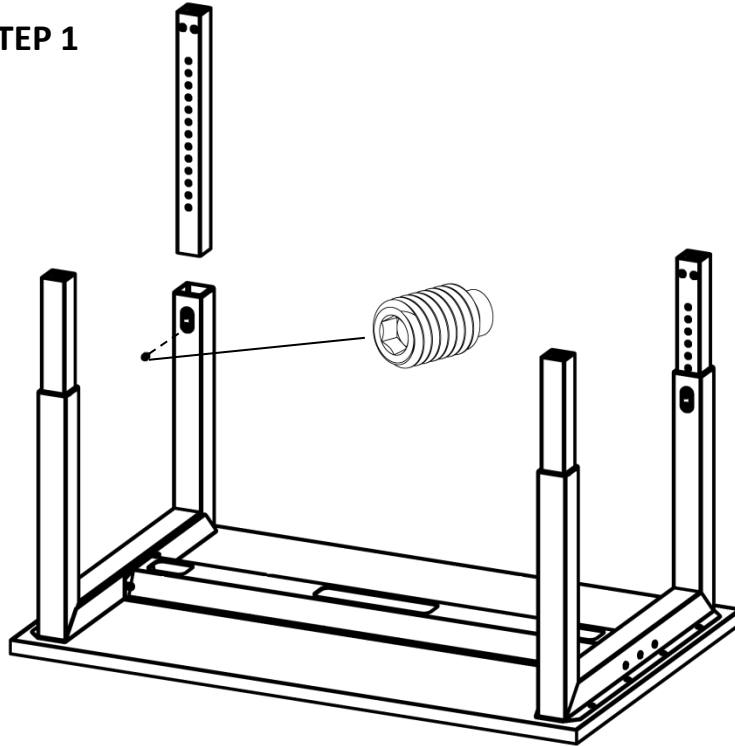

STEP 2

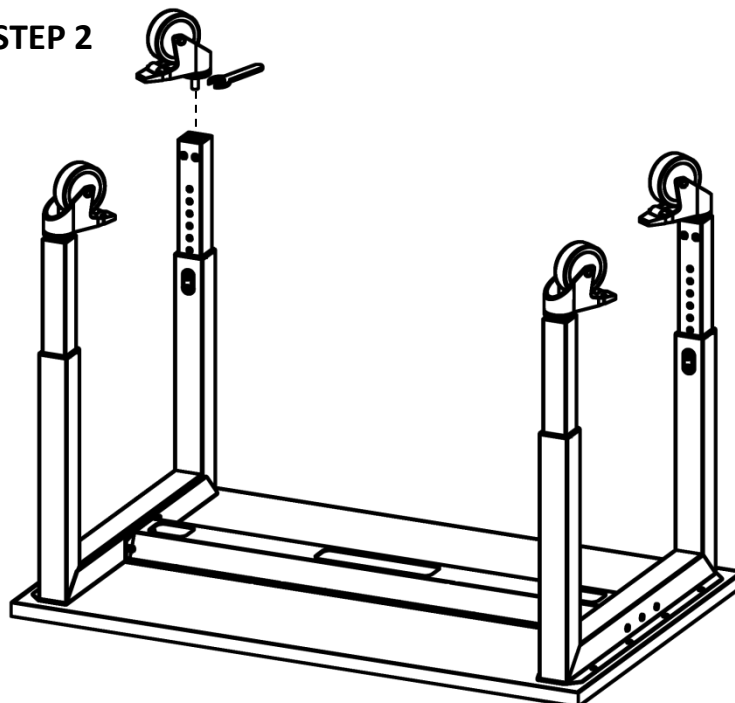

5. With a partner, team lift table and flip to the upright position.
Helpful Hint: Lock all casters to prevent unexpected rolling when table legs touch down.

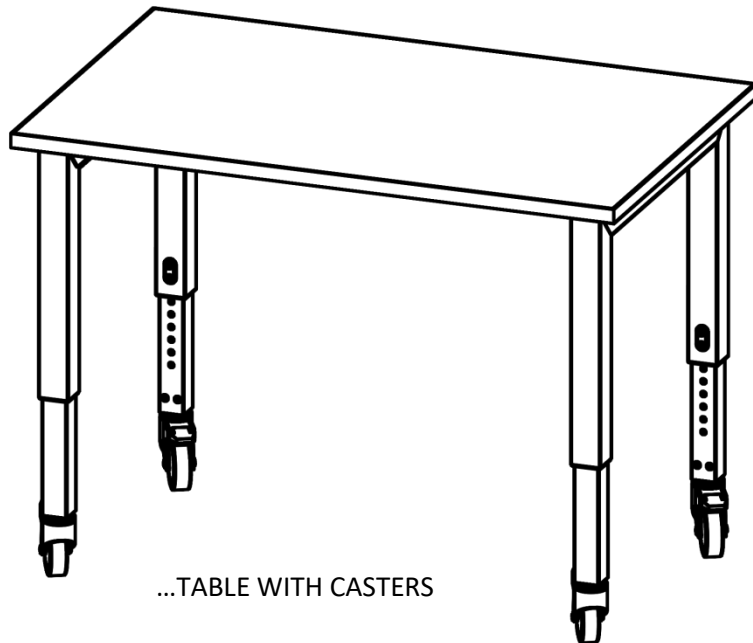
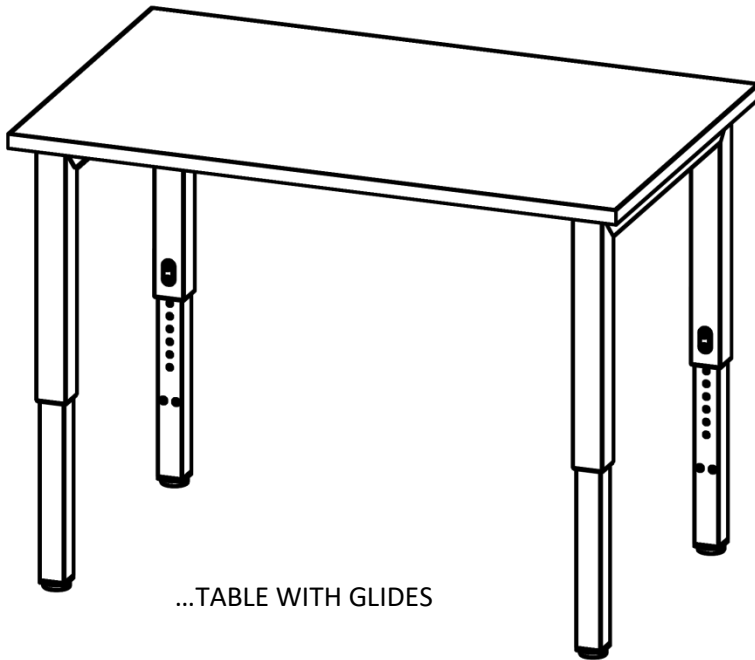

ASSEMBLY COMPLETE